



*Digital Download*

ANSI/TPI 1-2014 (Electronic Read-Only Standard):  
National Design Standard for Metal  
Plate Connected Wood Truss  
Construction – Standard Only

*(Note: This electronic version/digital download is a read-only version of just the Standard and does not include the Commentary. This digital download is a single user license only and is not to be networked. To order the full version (Standard & Commentary) of this publication or other TPI offerings please visit [www.tpinst.org](http://www.tpinst.org).)*

---

218 N. Lee Street, Ste. 312, Alexandria, VA 22314 – 703/683-1010 – [www.tpinst.org](http://www.tpinst.org)

*Copyright TPI. Single user Read-Only document. Reproduction & networking prohibited. See Terms & Conditions at [www.tpinst.org/terms-conditions/](http://www.tpinst.org/terms-conditions/).*



#### Digital Products Terms & Conditions:

All digital products from the TPI Website that are available for download, either for purchase or free, are offered under the following conditions:

- The digital file may be downloaded once for personal use and, in the case of printable files, one hard copy of the downloadable file may be produced for personal use,
- The purchaser may not otherwise reproduce, resell, network, or reconvey, nor grant others permission to download or reproduce the file or files,
- The publications and files are owned by the Truss Plate Institute and all rights are retained, and
- All digital download sales are final as per TPI's Return Policy (see TPI Website for policy).

By having downloaded this digital document you agree to these terms and conditions.

You have the Read-Only version of the TPI 1 Standard but you're missing the full story.

# Get the Complete Picture on Metal Plate Connected Wood Trusses (MPCWT)



## **Design Standard & Quality Criteria** **Complete ANSI/TPI 1 plus Commentary & Appendices**

Contains the material in the read-only file plus the comprehensive Commentary & Appendices. The Commentary & Appendices provide invaluable insight into the rationale behind the building code referenced Standard. Available in print and electronic form. *(Produced by TPI)*



## **Bracing, Handling, & Safety** **Jobsite Packages & BCSI**

Contains building code referenced guidelines on the safe handling and installation of MPCWT. Important & necessary guides covering the industry's best practice for safe truss installation. *(Jointly produced by TPI & SBCA. Distributed by SBCA.)*

**Order today and get the full story!**

*Click the links below for more information & ordering options*

**Complete ANSI/TPI 1-2014**  
*(Produced by TPI)*

**Jobsite Packages & BCSI**  
*(Jointly produced by TPI & SBCA)*



Revision of ANSI/TPI 1-2007

*American National Standard*

---

**NATIONAL DESIGN  
STANDARD  
FOR  
METAL PLATE CONNECTED  
WOOD TRUSS CONSTRUCTION**



**Truss Plate Institute**  
Connecting the Truss Industry

## 2014 TRUSS PLATE INSTITUTE MEMBERS

### **CHEROKEE METAL PRODUCTS, INC.**

www.masengills.com  
Morristown, TN  
(423) 586-7831

### **MITEK USA, INC.**

www.mitek-us.com  
Chesterfield, MO  
(314) 434-1200

### **EAGLE METAL PRODUCTS**

www.eaglemetal.com  
Dallas, TX  
(800) 521-3245

### **SIMPSON STRONG-TIE COMPANY INC.**

www.strongtie.com  
Pleasanton, CA  
(800) 999-5099

### **ALPINE, AN ITW COMPANY**

www.alpineitw.com  
Earth City, MO  
(800) 521-9790



**Truss Plate Institute**  
*Connecting the Truss Industry*

218 North Lee Street, Ste. 312  
Alexandria, VA 22314  
(703) 683-1010  
www.tpinst.org

Copyright © 2014 by the Truss Plate Institute, Inc.

All rights reserved.

This book or any part thereof must not be reproduced in any form without the written permission of the publisher.

Printed in the United States of America

## FOREWORD

(This Foreword is not part of American National Standard ANSI/TPI 1-2014)

An association of manufacturers actively engaged in the production of metal connector plates for the wood truss industry, and individuals or firms engaged in related activities, the Truss Plate Institute was organized in 1961 for the purpose of maintaining the wood truss industry on a sound engineering basis. To accomplish its purpose, the Institute establishes methods of design and construction for wood trusses using metal connector plates, supports and disseminates test and research data, assists in the development of proper building code regulations, recommends quality control standards, and distributes information on the use of metal-plate-connected wood trusses in the interest of public safety.

Both Imperial (inches and pounds) and SI (millimeters and Newtons) have been included in this document to facilitate its use by a wider audience. The intent is not to require dual units to be shown on all drawings and designs; rather, the intent is to allow the designer to use whichever system of measure is most useful for a given project. The dual system also allows the designer to comply with the United States Federal Government mandate for use of metric units on all federal projects.

Structural components covered in this document are wood trusses using metal plate connectors at their joints. Metal-plate-connected/metal web wood trusses, steel pin connected pipe web trusses and other structural elements are expressly excluded from this Standard. Appendices to this Standard are non-mandatory and are not part of this Standard.

It is the sole responsibility of the user to apply the criteria in this Standard. The Truss Plate Institute and the metal-plate-connected wood truss industry at large expressly disclaim any liability arising from the use, application or reference to the present document. For the most recent updates, errata, and addendums, refer to the TPI website at [www.tpinst.org](http://www.tpinst.org).

## TARGET AUDIENCE

This ANSI/TPI 1-2014, *National Design Standard for Metal Plate Connected Wood Truss Construction* has been developed primarily for use by professional engineers and architects involved in the design of metal-plate-connected wood trusses. This document will also serve the truss manufacturer, and aid building officials, approved quality assurance agencies, and building engineers or architects of record.

## ACKNOWLEDGMENTS

TPI would like to acknowledge the efforts of its Technical Advisory Committee and its ANSI accredited Project Committee and its contributing participants for their many hours of work in developing this Standard. Thanks also go out to those participating in ANSI's "Standards Action" call for comment on this ANSI/TPI 1-2014.

This Standard was processed and approved for submittal to ANSI by the Accredited Truss Plate Institute's Project Committee. Project Committee approval of this Standard does not necessarily imply that all committee members voted for its approval. At the time it approved this standard, TPI Project Committee had the following membership.

## ANSI/TPI 1-2014 PROJECT COMMITTEE MEMBERS

Chairman: David Brakeman, *ITW Building Components Group, Inc.*

Noel Baca, *NCSEA*

Larry Beineke, *PFS Corporation*

Don Bender, *Washington State University*

Junaidie Budiman, *Trussway Holding Inc.*

Dionel Cotanda, *Robins Manufacturing Company*

Steven Cramer, *University of Wisconsin-Madison*

Bob Dayhoff, *Shelter Systems Limited*

Ryan Dexter, *SBCRI*

Johnny Drozdek, *Simpson Strong-Tie Co.*

Gary Ehrlich, *National Association of Home Builders*

Howard Gauger, *R&D Thiel / CCA*

Samuel A. Greenberg, *Dansco Engineering, LLC*

John Gruber, *Sheppard Engineering, PC*

Kirk Grundahl, *Structural Building Components Association*

Art Hernandez, *Eagle Metal Products*

Steve A. Kennedy, *Lumber Specialties Ltd.*

John Kozal, *Universal Forest Products, Inc.*

Stuart Lewis, *ITW Building Components Group, Inc.*

Michael Magid, *MiTek Industries, Inc.*

Gary Obudzinski, *ITW Building Components Group, Inc.*

Michael O'Reardon, *ICC Evaluation Service, Inc.*

Timothy W. Ott, *Nelson Architectural Engineers, Inc.*

Kent Pagel, *Pagel, Davis & Hill, P.C. Attorneys*

Timothy Riegel, *Rigidply Rafters, Inc.*

Marvin Strzyzewski, *MiTek Industries, Inc.*

Matt Vinson, *Eagle Metal Products*

Jim Vogt, *Qualtim, Inc.*

David Wert, *MiTek Industries, Inc.*

Larry Wilder, *Cherokee Metal Products, Inc.*

## AMERICAN NATIONAL STANDARD

Approval of an American National Standard requires verification by ANSI that the requirements for due process, consensus, and other criteria for approval have been met by the standards developer. This approval occurred August 27, 2014.

Consensus is established when, in the judgment of the ANSI Board of Standards Review, substantial agreement has been reached by directly and materially affected interests. Substantial agreement means much more than a simple majority, but not necessarily unanimity. Consensus requires that all views and objections be considered, and that a concerted effort be made toward their resolution.

The use of American National Standards is completely voluntary; their existence does not in any respect preclude anyone, whether s/he has approved the standards or not, from manufacturing, marketing, purchasing, or using products, processes, or procedures not conforming to the standards.

The American National Standards Institute does not develop standards and will in no circumstances give an interpretation of any American National Standard. Moreover, no person shall have the right or authority to issue an interpretation of an American National Standard in the name of the American National Standards Institute. Requests for interpretations should be addressed to the secretariat or sponsor whose name appears on the title page of this standard.

**CAUTION NOTICE:** This American National Standard may be revised or withdrawn at any time. The procedures of the American National Standards Institute require that action be taken periodically to reaffirm, revise, or withdraw this standard. Purchasers of American National Standards may receive current information on all standards by calling or writing the American National Standards Institute.

Published by:

Truss Plate Institute

218 North Lee Street, Ste. 312

Alexandria, VA 22314

(703) 683-1010

[www.tpinst.org](http://www.tpinst.org)

Copyright © 2014 by the Truss Plate Institute, Inc.

All rights reserved.

This book or any part thereof must not be reproduced in any form without the written permission of the publisher.

Printed in the United States of America



**CHAPTER LIST****CHAPTER 1**

GENERAL ..... 1

**CHAPTER 2**STANDARD RESPONSIBILITIES IN THE DESIGN AND APPLICATION OF METAL-PLATE-CONNECTED  
WOOD TRUSSES ..... 9**CHAPTER 3**

QUALITY CRITERIA FOR THE MANUFACTURE OF METAL-PLATE-CONNECTED WOOD TRUSSES . . . 17

**CHAPTER 4**

METAL CONNECTOR PLATE MANUFACTURING ..... 27

**CHAPTER 5**

PERFORMANCE EVALUATION OF METAL CONNECTOR PLATED CONNECTIONS..... 31

**CHAPTER 6**

MATERIALS AND GENERAL DESIGN CONSIDERATIONS ..... 47

**CHAPTER 7**

MEMBER DESIGN PROCEDURES ..... 55

**CHAPTER 8**

METAL CONNECTOR PLATE JOINT DESIGN ..... 71

## TABLE OF CONTENTS

2014 TRUSS PLATE INSTITUTE MEMBERS . . . . .	Preface
FOREWORD . . . . .	i
TARGET AUDIENCE . . . . .	i
ACKNOWLEDGMENTS . . . . .	i
ANSI/TPI 1-2014 PROJECT COMMITTEE MEMBERS . . . . .	ii
AMERICAN NATIONAL STANDARD . . . . .	iii

## CHAPTER 1

<b>GENERAL . . . . .</b>	<b>1</b>
1.1 INTRODUCTION . . . . .	1
1.2 DEVELOPMENT . . . . .	1
1.3 GENERAL . . . . .	1
1.3.1 Scope . . . . .	1
1.3.2 Alternate Provisions . . . . .	1
1.3.2.1 Materials, Assemblies, Structures, and Designs . . . . .	1
1.3.2.2 Responsibilities . . . . .	1
1.4 REFERENCED STANDARDS . . . . .	1
1.5 NOTATION AND SYMBOLS . . . . .	2
1.6 DEFINITIONS . . . . .	6
1.7 CONVERSION FACTORS . . . . .	8

## CHAPTER 2

### STANDARD RESPONSIBILITIES IN THE DESIGN AND APPLICATION OF METAL-PLATE-CONNECTED WOOD TRUSSES . . . . .

<b>OF METAL-PLATE-CONNECTED WOOD TRUSSES . . . . .</b>	<b>9</b>
2.1 GENERAL PURPOSES . . . . .	9
2.2 DEFINITIONS . . . . .	9
2.3 RESPONSIBILITIES . . . . .	11
2.3.1 Requirements of the Owner . . . . .	11
2.3.1.1 Building Permit . . . . .	11
2.3.1.2 Registered Design Professional Designation . . . . .	11
2.3.1.3 Engagement with the Building Designer . . . . .	11
2.3.1.4 Engagement with the Contractor . . . . .	11
2.3.1.5 Review and Coordinate Submittal Packages . . . . .	11
2.3.1.6 Long Span Truss Requirements . . . . .	11
2.3.1.6.1 Restraint/Bracing Design . . . . .	11
2.3.1.6.2 Special Inspection . . . . .	11
2.3.1.7 Responsibility Exemptions . . . . .	11
2.3.2 Requirements of the Building Designer . . . . .	11
2.3.2.1 Construction Documents . . . . .	11
2.3.2.2 Deferred Submittals . . . . .	11
2.3.2.3 Review Submittal Packages . . . . .	11
2.3.2.4 Required Information in the Construction Documents . . . . .	11
2.3.2.5 Responsibility Exemptions . . . . .	12
2.3.3 Requirements for the Permanent Member	
Restraint/Bracing of Truss Systems . . . . .	12
2.3.3.1 Method of Restraint . . . . .	12
2.3.3.1.1 Standard Industry Details . . . . .	12

2.3.3.1.2	Substitution with Reinforcement. . . . .	12
2.3.3.1.3	Project Specific Design. . . . .	12
2.3.3.2	Absence of Truss Restraint/Bracing Method or Details. . . . .	12
2.3.3.3	Trusses Spanning 60 Feet (18 m) or Greater. . . . .	12
2.3.4	Requirements of the Contractor. . . . .	13
2.3.4.1	Information Provided to the Truss Manufacturer. . . . .	13
2.3.4.2	Information Provided to the Building Designer. . . . .	13
2.3.4.3	Truss Submittal Package Review. . . . .	13
2.3.4.4	Means and Methods. . . . .	13
2.3.4.5	Truss Installation. . . . .	13
2.3.4.6	Pre-Installation Check. . . . .	13
2.3.4.7	Post-Installation Check. . . . .	13
2.3.4.8	Truss Damage Discovery. . . . .	13
2.3.4.9	Truss Damage Responsibilities. . . . .	13
2.3.4.10	Responsibility Exemptions. . . . .	13
2.3.5	Requirements of the Truss Designer. . . . .	13
2.3.5.1	Preparation of Truss Design Drawings. . . . .	13
2.3.5.2	Single Truss Component Design. . . . .	14
2.3.5.3	Truss Design Drawing Seal and Signature. . . . .	14
2.3.5.4	Truss Placement Diagram. . . . .	14
2.3.5.5	Information on Truss Design Drawings. . . . .	14
2.3.5.6	Responsibility Exemptions. . . . .	14
2.3.6	Requirements of the Truss Manufacturer. . . . .	14
2.3.6.1	Truss Design Criteria and Requirements. . . . .	14
2.3.6.2	Communication to Truss Designer. . . . .	15
2.3.6.3	Alternate Truss Designs. . . . .	15
2.3.6.4	Truss Placement Diagram. . . . .	15
2.3.6.5	Required Documents. . . . .	15
2.3.6.6	Special Application Conditions. . . . .	15
2.3.6.7	Truss Submittal Packages. . . . .	15
2.3.6.8	Reliance on Construction Documents. . . . .	15
2.3.6.9	Fabrication Tolerance. . . . .	15
2.3.6.10	Manufacturer Quality Criteria. . . . .	15
2.3.6.11	In-Plant Truss Inspections. . . . .	15
2.3.6.12	Responsibility Exemptions. . . . .	15
2.4	CONTRACTS . . . . .	15
2.4.1	Defer to Construction Documents. . . . .	15
2.4.2	Defer to Contract. . . . .	15
2.4.3	Incorporation into Contract. . . . .	16

**CHAPTER 3**  
**QUALITY CRITERIA FOR THE MANUFACTURE**  
**OF METAL-PLATE-CONNECTED WOOD TRUSSES . . . . . 17**

3.1	GENERAL . . . . .	17
3.1.1	Scope. . . . .	17
3.1.2	Requirements. . . . .	17
3.1.3	Documentation. . . . .	17
3.1.4	Non-Conforming Inspections. . . . .	17

3.2	IN-PLANT QUALITY ASSURANCE PROGRAM. . . . .	17
3.2.1	In-Plant Quality Control Manual. . . . .	17
3.2.2	Inspection Frequency. . . . .	17
3.2.3	Inspection Sampling. . . . .	17
3.2.4	Inspection Procedure. . . . .	17
3.3	TRUSS DESIGN . . . . .	17
3.3.1	Truss Design Drawing. . . . .	17
3.3.2	Fabrication Tolerance. . . . .	17
3.3.3	Roller Press Value Reduction. . . . .	17
3.4	LUMBER. . . . .	18
3.4.1	Lumber Specifications. . . . .	18
3.4.2	Lumber Substitutions. . . . .	18
3.4.3	Lumber Identification. . . . .	18
3.4.4	Preservative Treatment Identification. . . . .	18
3.4.5	Fire Retardant Identification. . . . .	18
3.4.6	Use of Finger-Jointed Lumber. . . . .	18
3.4.7	Lumber Splits. . . . .	18
3.5	ASSEMBLY . . . . .	18
3.5.1	General. . . . .	18
3.5.2	Wood Members. . . . .	19
3.5.3	Height and Length. . . . .	19
3.6	PLATING OF JOINTS . . . . .	19
3.6.1	Storage and Care. . . . .	19
3.6.2	Specifications. . . . .	19
3.6.3	Substitutions. . . . .	19
3.6.4	Installation. . . . .	19
3.6.5	Plate Position. . . . .	19
3.7	JOINT INSPECTION . . . . .	19
3.7.1	Critical Joint Inspection. . . . .	19
3.7.2	Plate Positioning Procedures. . . . .	20
3.7.2.1	Plate Placement. . . . .	20
3.7.2.2	Alternative Positioning Procedure. . . . .	20
3.7.3	Plate Rotation. . . . .	20
3.7.4	Plate Contact Area. . . . .	20
3.7.4.1	Lumber Characteristics and Tooth Flattening. . . . .	20
3.7.4.2	Fabrication Tolerance Exceeded Tooth Count. . . . .	22
3.7.5	Plate Embedment. . . . .	22
3.7.5.1	Plate Embedment Gap Tolerance. . . . .	22
3.7.5.2	Excessive Embedment Gap Tooth Count. . . . .	22
3.7.6	Wood Member-To-Wood Member Gaps. . . . .	22
3.7.6.1	Tolerance. . . . .	22
3.7.6.2	Compression Load Tolerance. . . . .	23
3.7.6.3	Correction Procedure. . . . .	23
3.7.7	Effective Tooth Count. . . . .	23
3.7.7.1	Total Effective Teeth. . . . .	23
3.7.7.2	Number of Effective Teeth. . . . .	24
3.7.7.2.1	Ineffective Teeth – Lumber Characteristics. . . . .	24

3.7.7.2.2 Ineffective Teeth – End and Edge Distances..... 24

3.7.7.2.3 Ineffective Teeth – Tooth Flattening..... 24

3.7.7.2.4 Ineffective Teeth – Embedment Gap..... 24

3.7.8 Re-evaluation..... 25

3.8 REPRESSING..... 25

3.9 REPAIR..... 25

3.9.1 Repair Specifications..... 25

3.9.2 Plate Removal..... 25

3.9.3 Lumber Condition..... 25

3.10 GIRDER TRUSS PLY-TO-PLY CONNECTIONS..... 25

**CHAPTER 4**

**METAL CONNECTOR PLATE MANUFACTURING..... 27**

4.1 GENERAL..... 27

4.1.1 Scope..... 27

4.1.2 Requirements..... 27

4.2 QUALITY ASSURANCE PROGRAM (QAP)..... 27

4.2.1 Documentation..... 27

4.2.2 QAP Manager..... 27

4.2.2.1 Selection..... 27

4.2.2.2 Delegation..... 27

4.2.2.3 Authority..... 27

4.2.2.4 Responsibility..... 27

4.2.2.5 Record Retention..... 27

4.3 PRODUCTION STEEL..... 27

4.3.1 Specifications..... 27

4.3.2 Master Coil..... 27

4.3.2.1 Certification..... 27

4.3.2.2 Identification..... 27

4.3.3 Steel Sheet..... 27

4.3.3.1 Requirements..... 27

4.3.3.2 Hot-Dip Galvanized Steel..... 27

4.3.3.3 Electrolytic Galvanized Steel..... 27

4.3.3.4 Aluminum-Zinc Alloy Coated Steel..... 28

4.3.3.5 Stainless Steel..... 28

4.3.4 Steel Thickness..... 28

4.3.5 Records..... 28

4.3.6 Nail-on Plates..... 28

4.3.7 Tooth Tolerances..... 28

4.3.8 Marking..... 28

4.3.9 Regalvanizing..... 28

4.4 PRODUCTION..... 28

4.4.1 Measurement..... 28

4.4.2 Visual Observations..... 28

4.5 IDENTIFICATION..... 28

4.5.1 Plate Markings..... 28

4.5.2 Package Markings..... 28

4.6 INSPECTION..... 28

4.6.1 Frequency..... 28

4.6.2 Requirements. . . . . 29

4.7 TOLERANCES. . . . . 29

4.8 ACCEPTANCE . . . . . 29

4.9 REJECTION. . . . . 29

4.9.1 Nonconforming Metal Connector Plates. . . . . 29

4.9.2 Sampling Previous Production. . . . . 29

**CHAPTER 5**

**PERFORMANCE EVALUATION OF METAL**

**CONNECTOR PLATED CONNECTIONS . . . . . 31**

5.1 GENERAL . . . . . 31

5.1.1 Scope. . . . . 31

5.1.2 Testing Apparatus Requirements. . . . . 31

5.1.2.1 General. . . . . 31

5.1.2.2 Testing Machine. . . . . 31

5.1.2.3 Hydraulically Driven Testing Machine. . . . . 31

5.1.2.4 Gripping Devices. . . . . 31

5.1.2.5 Measuring Devices. . . . . 31

5.2 STANDARD METHOD OF TEST FOR DETERMINING LATERAL RESISTANCE OF METAL CONNECTOR PLATE TEETH . . . . . 31

5.2.1 Calculation Permitted For Nail-on Plates. . . . . 31

5.2.2 Metal Connector Plates. . . . . 31

5.2.2.1 Test Specimen Selection. . . . . 31

5.2.2.2 Cleaning Plates. . . . . 32

5.2.2.3 Test Specimen Design. . . . . 32

5.2.2.4 Number of Samples. . . . . 32

5.2.3 Solid Metal Control Specimens. . . . . 32

5.2.3.1 Number of Samples. . . . . 32

5.2.3.2 Control Specimen. . . . . 32

5.2.4 Wood Members. . . . . 32

5.2.4.1 General. . . . . 32

5.2.4.2 Test Specimen Characteristics. . . . . 32

5.2.4.3 Clear Wood Under Plates. . . . . 32

5.2.4.4 Test Specimen Length. . . . . 32

5.2.4.5 Number of Samples. . . . . 32

5.2.5 Embedment Methods. . . . . 32

5.2.5.1 Design Values. . . . . 32

5.2.5.2 Reduction Value. . . . . 33

5.2.6 Test Specimen Fabrication. . . . . 33

5.2.6.1 Plate Thickness. . . . . 33

5.2.6.2 Assembly. . . . . 33

5.2.6.2.1 Gross Area Method. . . . . 33

5.2.6.2.2 Net Area Method. . . . . 33

5.2.6.3 Full Contact of Wood Members. . . . . 33

5.2.6.4 Joint Fabrication Setup. . . . . 33

5.2.6.5 Plate Embedment. . . . . 36

5.2.6.6 Wood-to-Plate Slip. . . . . 36

5.2.6.7 Structural Composite Lumber. . . . . 36

5.2.7 Test Specimens Required. . . . . 36

5.2.7.1	Wide Face Lateral Resistance Values.....	36
5.2.7.1.1	Replicates and Orientations.....	36
5.2.7.1.2	Symmetrical Plate Teeth.....	36
5.2.7.2	Narrow Face Lateral Resistance Values.....	36
5.2.7.2.1	Gross Area Tests.....	36
5.2.7.2.2	Alternative.....	37
5.2.8	Test Procedure to Determine Lateral Strength Capacities.....	37
5.2.8.1	Measurements.....	37
5.2.8.2	Time Period.....	37
5.2.8.3	Loading Procedure.....	37
5.2.8.4	Testing Procedure for Solid Metal Control Specimens.....	37
5.2.9	Calculations.....	37
5.2.9.1	General.....	37
5.2.9.2	Lateral Resistance Design Values.....	37
5.2.9.3	Adjustment Factor for Specific Gravity of Test Specimens Exceeding Specified Value ( $R_G$ ).....	37
5.2.10	Report.....	37
ANNEX A5.2: DESIGN VALUE ADJUSTMENTS FOR SINGLE PASS ROLLER PRESSES (MANDATORY INFORMATION).....		38
A5.2.1	Scope.....	38
A5.2.2	Sampling.....	38
A5.2.2.1	Number of Samples.....	38
A5.2.2.2	Matched Test Specimen Pairs.....	38
A5.2.2.3	Materials.....	38
A.5.2.3	Test Specimens Required.....	38
A5.2.3.1	Property Evaluated.....	38
A5.2.3.2	Species.....	38
A5.2.3.3	Plate Type.....	39
A5.2.3.4	Roller Presses.....	39
A5.2.4	Test Specimen Fabrication.....	39
A5.2.4.1	General.....	39
A5.2.4.2	Roller Test Specimens.....	39
A5.2.5	Test Procedure.....	39
A5.2.5.1	General.....	39
A5.2.5.2	Test Specimen Pairs.....	39
A5.2.5.3	Tooth Withdrawal Failure.....	39
A5.2.6	Calculations.....	40
A5.2.6.1	Strength Adjustment Ratios, ( $Q_R$ ).....	40
A5.2.6.2	Plate Design Values.....	40
A5.2.6.3	$Q_R$ Application.....	40
A5.2.7	Report.....	40
5.3	STANDARD METHOD OF TEST FOR STRENGTH PROPERTIES OF METAL CONNECTOR PLATES UNDER SHEAR FORCE.....	40
5.3.1	Scope.....	40
5.3.2	Metal Connector Plates.....	40
5.3.2.1	Test Specimen Selection.....	40
5.3.2.2	Test Coil Steel.....	40
5.3.3	Solid Metal Control Specimens.....	40
5.3.3.1	Number of Samples.....	40

5.3.3.2	Control Specimen.....	40
5.3.4	Test Specimen Fabrication.....	40
5.3.4.1	General.....	40
5.3.4.2	General Orientation.....	41
5.3.4.3	Less Than 90 Degree Orientation.....	41
5.3.4.4	Greater Than 90 Degree Orientation.....	41
5.3.4.5	Metal Connector Plate Length.....	41
5.3.4.6	Plate Embedment.....	42
5.3.4.7	Embedment Procedure.....	42
5.3.4.8	Joints.....	42
5.3.5	Test Specimens Required.....	42
5.3.6	Test Procedure.....	42
5.3.6.1	General Measurements.....	42
5.3.6.2	Angles.....	42
5.3.6.3	Set-Up.....	42
5.3.6.4	Testing Procedure for Solid Metal Control Specimens.....	42
5.3.6.5	Maximum Loads.....	42
5.3.7	Calculations.....	42
5.3.7.1	Ultimate Tensile Strength - Control Specimen.....	42
5.3.7.2	Theoretical Ultimate Shear Stress - Control Specimen.....	42
5.3.7.3	Ultimate Shear Strength - Test Specimen.....	42
5.3.7.4	Shear Strength Effectiveness Ratio.....	43
5.3.8	Report.....	43
5.4	STANDARD METHOD OF TEST FOR STRENGTH PROPERTIES OF METAL CONNECTOR PLATES UNDER TENSION FORCES.....	43
5.4.1	Scope.....	43
5.4.1.1	Geometric Efficiency.....	43
5.4.1.2	Chain of Holes Extending in Diagonal or Zigzag Line.....	43
5.4.2	Metal Connector Plates.....	43
5.4.2.1	Test Specimen Selection.....	43
5.4.2.2	Test Coil Steel.....	44
5.4.3	Solid Metal Control Specimens.....	44
5.4.3.1	Number of Samples.....	44
5.4.3.2	Control Specimens.....	44
5.4.4	Test Specimen Fabrication.....	44
5.4.4.1	Minimum Thickness.....	44
5.4.4.2	Test Specimen Assembly.....	44
5.4.4.2.1	Non-Standard Test Specimens.....	44
5.4.4.3	Metal Connector Plate Length.....	44
5.4.5	Test Specimens Required.....	44
5.4.5.1	Across Plate Width.....	44
5.4.5.2	Across Plate Length.....	44
5.4.6	Test Procedure.....	45
5.4.6.1	Measurements.....	45
5.4.6.2	Loading Procedure.....	45
5.4.6.3	Testing Procedure for Solid Metal Control Specimens.....	45
5.4.6.4	Maximum Loads.....	45
5.4.7	Calculations.....	45



5.4.7.1	Ultimate Tensile Strength - Test Specimen. . . . .	45
5.4.7.2	Ultimate Tensile Strength - Control Specimen. . . . .	45
5.4.7.3	Tensile Effectiveness Ratio. . . . .	46
5.4.7.3.1	Non-Standard Test Specimens. . . . .	46
5.4.8	Geometric Efficiency. . . . .	46
5.4.8.1	Definition. . . . .	46
5.4.8.2	Chain of Holes Extending in Diagonal or Zigzag Line. . . . .	46
5.4.9	Report. . . . .	46

## CHAPTER 6

### MATERIALS AND GENERAL DESIGN CONSIDERATIONS . . . . . 47

6.1	GENERAL. . . . .	47
6.1.1	Structural Analysis. . . . .	47
6.1.1.1	Mathematical Model. . . . .	47
6.1.1.2	Structural Analysis Method. . . . .	47
6.1.2	Truss Design Information. . . . .	47
6.2	LOADS. . . . .	47
6.2.1	General Loading Requirements. . . . .	47
6.2.2	Loading Requirements for Metal-Plate-Connected Wood Trusses. . . . .	47
6.2.2.1	Non-Bearing Partitions. . . . .	47
6.2.2.1.1	Non-Bearing Partition Weight Not Permitted to be Ignored. . . . .	47
6.2.2.1.2	Non-Load Bearing Partitions Parallel to Supporting Trusses. . . . .	47
6.2.2.2	Effect of Pitch. . . . .	47
6.2.2.3	Dead Loads for Determining Wind Uplift. . . . .	47
6.2.2.4	Full- and Partial-Length Live Loading. . . . .	48
6.2.2.5	Out-of-Plane Loading. . . . .	48
6.2.2.5.1	Loads through Chord-to-Chord Joints at Unblocked Diaphragm Joints. . . . .	48
6.3	DESIGN VALUES . . . . .	48
6.3.1	Design Values for Solid Sawn Lumber. . . . .	48
6.3.2	Design Values for Structural Composite Lumber. . . . .	48
6.3.3	Design Values for Fasteners Other Than Metal Connector Plates. . . . .	48
6.3.4	Design Values for Metal Connector Plates. . . . .	48
6.3.4.1	Allowable Steel Stresses. . . . .	48
6.3.4.1.1	Tensile Stress. . . . .	48
6.3.4.1.2	Shear Stress. . . . .	48
6.3.4.1.3	Design Thickness. . . . .	48
6.3.4.2	Allowable Lateral Resistance Stresses. . . . .	49
6.4	ADJUSTMENTS TO DESIGN VALUES . . . . .	49
6.4.1	Load Duration Factor ( $C_D$ ) – for ASD only. . . . .	49
6.4.1.1	Applicability. . . . .	49
6.4.1.2	Design Values Affected. . . . .	50
6.4.1.3	Method. . . . .	50
6.4.1.4	Load Combinations. . . . .	50
6.4.2	Repetitive Member Increase ( $C_r$ ). . . . .	50
6.4.2.1	Definitions and Conditions for Use. . . . .	50
6.4.2.2	Limitations. . . . .	50
6.4.3	Bending Capacity Modification Factor ( $K_m$ ). . . . .	50
6.4.4	Flat Use Factor ( $C_{fu}$ ). . . . .	50

6.4.5	Buckling Stiffness Factor ( $C_T$ )	50
6.4.5.1	Conditions for Use	50
6.4.5.2	Method	51
6.4.6	Wet Service Factor ( $C_M$ )	51
6.4.6.1	Conditions for Use and Values	51
6.4.6.2	Exceptions	52
6.4.6.3	Moisture Content > 19% at the Time of Fabrication	52
6.4.7	Temperature Factor ( $C_t$ )	52
6.4.8	Incising Factor ( $C_i$ )	52
6.4.8.1	Conditions for Use	52
6.4.8.2	Reductions for the Design of Metal Connector Plates	52
6.4.9	Chemically Treated Lumber	52
6.4.9.1	Fire Retardant Treated (FRT) Lumber	52
6.4.9.2	Metal Connector Plates Installed in FRT	52
6.4.9.3	Preservative Treated Lumber	53
6.4.10	Quality Control Factor ( $C_q$ )	53
6.4.10.1	Applicability to Design Values	53
6.4.10.2	Conditions for Use	53
6.4.10.3	Modified Fabrication Tolerance	53
6.4.11	Load and Resistance Factor Design (LRFD)	53
6.4.12	Other Adjustment Factors	54
6.5	CORROSIVE ENVIRONMENTS	54
6.5.1	Recognized Coatings	54
6.5.2	Application of Coating	54
6.5.3	Stress Corrosion Cracking	54
6.6	USE OF METAL CONNECTOR PLATES IN CONVENTIONAL WALLS	54
6.6.1	Conditions for Use	54
6.6.2	Cutting and Notching	54

## CHAPTER 7

<b>MEMBER DESIGN PROCEDURES</b>	<b>55</b>	
7.1	SCOPE	55
7.2	EFFECTIVE BUCKLING LENGTHS	55
7.2.1	Effective Buckling Lengths for Chord Members	55
7.2.1.1	Chord Member Panels Not Subject to Sidesway	55
7.2.1.2	Chord Member Panels Subject to Sidesway	55
7.2.2	Effective Buckling Lengths for Web Members	55
7.2.2.1	Buckling in the Plane of the Truss	55
7.2.2.2	Buckling out of the Plane of the Truss	56
7.3	MEMBER DESIGN	57
7.3.1	Tension Members	57
7.3.2	Compression Members	57
7.3.3	Bending Members	58
7.3.3.1	Design Requirements	58
7.3.3.2	$L_u$ Value When Depth Exceeds Breadth	58
7.3.3.3	$L_u$ Not Required When Depth Does Not Exceed Breadth	58
7.3.3.4	Fully Supported Bending Members	58

7.3.3.5	Bottom Chord Bending Members. . . . .	58
7.3.3.6	Panel Point Moment Region at the Heel. . . . .	59
7.3.3.7	Composite Action of Multiple Layers. . . . .	59
7.3.4	Combined Bending & Tension. . . . .	59
7.3.5	Combined Bending & Compression. . . . .	59
7.3.5.1	Design Requirements. . . . .	59
7.3.5.2	Chord Members Continuously Braced. . . . .	60
7.3.5.3	Chord Members Not Continuously Braced. . . . .	60
7.3.6	L/d Ratios for Compression & Tension Members. . . . .	60
7.3.7	Shear. . . . .	60
7.3.7.1	Design Requirements. . . . .	60
7.3.7.2	Tapered Bottom Chord Heel. . . . .	60
7.3.7.3	Scarf Cut Bearings. . . . .	60
7.3.7.4	Use of Metal Connector Plates to Resist Shear. . . . .	60
7.3.8	Bearing Perpendicular to Grain. . . . .	61
7.3.8.1	Design Requirements. . . . .	61
7.3.8.1.1	$d_2$ . . . . .	61
7.3.8.1.2	$d_1$ . . . . .	61
7.3.8.2	Bearing Area Factor. . . . .	62
7.3.8.3	Bearing Plate Increase Factor. . . . .	62
7.3.9	Bearing Parallel to Grain. . . . .	62
7.3.9.1	Design Requirements. . . . .	62
7.3.9.2	Additional Requirements. . . . .	62
7.3.10	Bearing at an Angle to Grain. . . . .	62
7.4	ALLOWABLE TRUSS REACTIONS. . . . .	64
7.4.1	Minimum Length of Bearing. . . . .	64
7.4.2	Top Chord Bearing Parallel Chord Trusses. . . . .	64
7.5	GIRDER TRUSS DESIGN. . . . .	65
7.5.1	General. . . . .	65
7.5.2	Girder Loading. . . . .	65
7.5.2.1	Application of Reactions onto Girder Trusses. . . . .	65
7.5.2.2	Applied Loads Based on the Most Critical Reaction. . . . .	65
7.5.2.3	Load Continuous Across All Plies. . . . .	65
7.5.2.4	Maximum Plies. . . . .	65
7.5.2.5	Location of the Applied Load. . . . .	65
7.5.3	Member Design. . . . .	65
7.5.3.1	General. . . . .	65
7.5.3.2	Design for Tension Perpendicular to Grain Forces. . . . .	65
7.5.3.2.1	Extent of Connection. . . . .	65
7.5.3.2.2	Alternate Extent of Connection. . . . .	66
7.5.3.2.3	Effective Depth Greater Than 85% of Member Depth. . . . .	66
7.5.3.3	Design for Tension Perpendicular to Grain. . . . .	66
7.5.3.3.1	Effective Depth Greater Than 85% of Member Depth. . . . .	66
7.5.3.4	Reduced Section. . . . .	66
7.5.3.5	Torsion. . . . .	67
7.5.3.6	Structural Framing Connections. . . . .	67
7.5.4	Truss-to-Truss Girder Connections. . . . .	67
7.5.5	Ply-to-Ply Connections. . . . .	67

7.5.5.1	Connection of Members.....	67
7.5.5.2	Design Load.....	67
7.5.5.3	Design for Withdrawal Load.....	68
7.5.5.4	Nail Spacing.....	68
7.5.5.5	Bolt Spacing.....	68
7.6	DEFLECTION.....	68
7.6.1	Method of Calculation.....	68
7.6.2	Vertical Deflection Limits.....	69
7.6.2.1	Designated Limits.....	69
7.6.2.2	Deflection Using Beam Formulas.....	69
7.6.2.3	Deflection Calculation for Parallel Chord Trusses.....	69
7.6.2.4	Strongbacking.....	69
7.6.3	Horizontal Deflection Limits.....	70

## CHAPTER 8

	<b>METAL CONNECTOR PLATE JOINT DESIGN.....</b>	<b>71</b>
8.1	SCOPE.....	71
8.2	MINIMUM AXIAL DESIGN FORCES.....	71
8.3	LATERAL RESISTANCE.....	71
8.3.1	General.....	71
8.3.2	Adjustments.....	71
8.3.2.1	Exclusion of Area under the Net Area Method.....	71
8.3.2.2	Additional Consideration at Heel Joints.....	71
8.3.3	Design.....	72
8.3.3.1	Number of Teeth Reported for Inspection.....	72
8.3.3.2	Load Applied at an Angle.....	72
8.3.3.3	Metal Connector Plates Resisting Member Compressive Forces.....	72
8.3.3.3.1	No Wood Member Present.....	73
8.3.3.3.2	Adjacent Members.....	73
8.4	TENSION.....	73
8.4.1	Account for Orientation.....	73
8.4.2	Method.....	73
8.4.3	Required Cross Section.....	73
8.4.3.1	Maximum Effective Width at Mid-Panel Tension Splices.....	74
8.4.3.2	Maximum Effective Width at Panel Point Tension Splices.....	74
8.4.3.3	Connector Plate Designed for Moment.....	74
8.5	SHEAR.....	74
8.5.1	General.....	74
8.5.2	Method.....	74
8.5.3	Required Cross Section.....	76
8.5.4	Shear Values Parallel and Perpendicular to the Major Axis.....	76
8.5.5	Combination of Shear Plates and Tension Plates.....	76
8.5.6	Prevention of Shear Buckling.....	76
8.6	COMBINED SHEAR-TENSION.....	76
8.7	COMBINED FLEXURE AND AXIAL LOADING.....	76
8.7.1	Design of Joints with Plates on Front and Back.....	76
8.7.1.1	Design of Steel Section for Effect of Moment.....	76
8.7.1.2	Design of Plate Lateral Resistance for.....	76

Effect of Moment.....	78
8.7.2 Design of Splice Joints with Plates on Top and Bottom .....	79
8.8 NET SECTION LUMBER CHECK (H') .....	79
8.8.1 Reduced Net Section Checks.....	79
8.8.2 Limit on Tension Introduced into a Wood Member.....	79
8.9 INTERACTION BETWEEN PLATES AND OTHER FASTENERS.....	80
8.9.1 Lumber Dowel Bearing Strength Increase.....	80
8.9.2 Bolts and Other Fasteners.....	80
8.10 TENSION PERPENDICULAR TO GRAIN.....	80
8.11 PLATE POSITIONING TOLERANCE .....	80
8.11.1 General.....	80
8.11.2 Joint QC Detail Information.....	81
8.11.3 Joint Stress Index.....	81
8.11.4 Minimum Plate Positioning Tolerance.....	81
8.11.5 Plate Rotation.....	81

## CHAPTER 1 GENERAL

### 1.1 INTRODUCTION

The Truss Plate Institute (TPI) has developed this *National Design Standard for Metal Plate Connected Wood Truss Construction* to provide state-of-the-art technical information and specifications on metal-plate-connected wood Truss design and manufacturing.

### 1.2 DEVELOPMENT

This Standard was prepared by a committee comprised of: Users - professional engineers; Producers - wood Truss Manufacturers, Metal Connector Plate manufacturers, lumber manufacturers, and structural hardware manufacturers; and General Interest - participants from universities, Building Code agencies, and others. It is based on the collective engineering knowledge and best data available upon attaining evidence of consensus.

### 1.3 GENERAL

#### 1.3.1 Scope.

This Standard establishes minimum requirements for the design and construction of metal-plate-connected wood Trusses. This Standard describes the materials used in a Truss, both lumber and steel, and design procedures for Truss members and joints. Responsibilities, methods for evaluating the Metal Connector Plates, and manufacturing quality assurance for the Trusses are also contained in this Standard.

#### 1.3.2 Alternate Provisions.

##### 1.3.2.1 Materials, Assemblies, Structures, and Designs.

This Standard does not intend to preclude the use of materials, assemblies, structures, or designs not meeting the criteria herein, when they demonstrate equivalent performance for the intended use to those specified in this Standard. The use of such alternate provisions shall be indicated on the Truss Design Drawing.

##### 1.3.2.2 Responsibilities.

The divisions of Responsibilities between the Truss Designer, Building Designer and others as defined in Chapter 2 and elsewhere in this Standard are not intended to preclude alternate provisions as agreed upon by the parties involved.

### 1.4 REFERENCED STANDARDS

*ACI530-11/ASCE5-11/TMS402-11*, Building Code Requirements for Masonry Structures.

*ANSI A108/ANSI A118/A136-2013*, Specifications for the Installation of Ceramic Tile.

*ANSI/AWC NDS-2012*, National Design Specification for Wood Construction & Supplement.

*ANSI A190.1-2007*, Standard for Wood Products - Structural Glued Laminated Timber.

*ANSI/ASCE 7-10*, Minimum Design Loads for Buildings and other Structures.

American Softwood Lumber Standard, Voluntary Product Standard *PS 20-10*, National Institute of Standards and Technology, U.S. Department of Commerce.

*ASTM A153/A153M-09*, Standard Specification for Zinc Coating (Hot-Dip) on Iron and Steel Hardware.

*ASTM A167-99 (2009)*, Standard Specification for Stainless and Heat-Resisting Chromium-Nickel Steel Plate, Sheet, and Strip.

*ASTM A240/A240M-12a*, Standard Specification for Chromium and Chromium-Nickel Stainless Steel Plate, Sheet, and Strip for Pressure Vessels and for General Applications.

*ASTM A879/879M-12*, Standard Specification for Steel Sheet, Zinc Coated by the Electrolytic Process for Applications Requiring Designation of the Coating Mass on Each Surface.

*ASTM A653/A653M-11*, Standard Specification for Steel Sheet, Zinc-Coated (Galvanized) or Zinc-Iron Alloy-Coated (Galvannealed) by the Hot-Dip Process.

*ASTM A792/A792M-10*, Standard Specification for Steel Sheet, 55% Aluminum-Zinc Alloy-Coated by the Hot-Dip Process.

*ASTM C840-11*, Standard Specification for Application and Finishing of Gypsum Board.

*ASTM D245-06 (2011)*, Standard Practice for Establishing Structural Grades and Related Allowable Properties for Visually Graded Lumber.

*ASTM D2395-07a*, Standard Test Methods for Specific Gravity of Wood and Wood-Base Materials.

*ASTM D2555-06 (2011)*, Standard Test Methods for Establishing Clear Wood Strength Values.

*ASTM D2559-12a*, Standard Specification for Adhesives for Bonded Structural Wood Products for Use Under Exterior Exposure Conditions.

*ASTM D4442-07*, Standard Test Methods for Direct Moisture Content Measurement of Wood and Wood-Base Materials.

*ASTM D7438-13*, Standard Practice for Field Calibration and Application of Hand Held Moisture Meters.

*ASTM D5456-12*, Standard Specification for Evaluation of Structural Composite Lumber Products.

*ASTM E4-13*, Standard Practices for Load Verification of Testing Machines.

*ASTM E8/E8M-11*, Standard Test Methods for Tension Testing of Metallic Materials.

*ASTM E631-06*, Standard Terminology of Building Constructions.

*BCSI*, Guide to Good Practice for Handling, Installing, Restraining & Bracing of Metal Plate Connected Wood Trusses.

*BCSI-B1*, Guide for Handling, Installing, Restraining & Bracing of Trusses.

*BCSI-B2*, Truss Installation & Temporary Restraint/Bracing.

*BCSI-B3*, Permanent Restraint/Bracing of Chords & Web Members.

*BCSI-B7*, Guide for Handling, Installing & Bracing of 3x2 and 4x2 Parallel Chord Trusses.

*BCSI-B10*, Post Frame Truss Installation, Restraint & Bracing.

## 1.5 NOTATION AND SYMBOLS

$A$	Cross-sectional area
$A_b$	Net bearing area
$A_{ef}$	Effective plate area on one face of each Wood Member at splice joint (see Section 8.7.1.2)
$A_{gc}$	Cross-sectional area of the solid metal control specimen
$A_{gp}$	Cross-sectional area of the Metal Connector Plate
$A_p$	Minimum required Metal Connector Plate contact area on Wood Members
AA, AE, EA, EE	Designations for orientation of plates with respect to tooth holding ( $V_{LR}$ ); see notations $V_{LRAA}$ , $V_{LRAE}$ , $V_{LREA}$ , and $V_{LREE}$
$B$	Width of bearing
$B_R$	Minimum required bearing width
$C$	Wood compression strength normal to joint line for design of plated joints subject to bending (see Section 8.7.1.1)
$C_b$	Bearing area factor
$C_D$	Load duration factor
$C_{fu}$	Flat use factor
$C_i$	Incising factor
$\mathcal{C}$	Centerline of Truss or member
$C_M$	Wet service factor
$C_m$	Factor to account for P-delta effects on chord splices subject to moment (see Section 8.7.1.1)
$C_{plate}$	Bearing plate increase factor
$C_q$	Quality control factor (see Section 6.4.10)
$C_r$	Repetitive member factor
$C_R$	Reduction factor for the compression force component across the joint interface

$C_s$	Compression force in steel across joint using a Truss plate subject to bending (see Section 8.7.1.1)	$F_c, F'_c$	Reference and adjusted design stress for compression parallel to grain
$C_T$	Buckling stiffness factor	$F_c^*$	Design stress for compression parallel to grain adjusted by modification factors
$C_t$	Temperature factor	$F_{c\perp}, F'_{c\perp}$	Reference and adjusted compression design stress perpendicular to grain
$C_w$	Compression force carried by wood-to-wood butting across joint using a Truss plate subject to bending (see Section 8.7.1.1)	$F_{cE}$	Critical buckling design stress for compression members
$c$	One-half the depth (d) of the Wood Member	$F_{sc}$	Theoretical ultimate shear strength of the solid metal control specimen ( $0.577F_{tc}$ )
$COV_E$	Coefficient of variation for modulus of elasticity	$F_{sp}$	Ultimate shear strength of the Metal Connector Plate
$D$	(1) Overall depth of Truss, (2) depth of chord at splice joint or (3) diagonal of a rectangular area with area of $A_{ef}$ (see Section 8.7.1.2)	$F_{st}$	Allowable tensile stress of the steel
$D_{PR}$	Gross dimension of the Metal Connector Plate measured perpendicular to the Wood Member's grain	$F_t, F'_t$	Reference and adjusted tension design stress parallel to grain
$d$	(1) Dowel diameter or (2) critical dimension of the rectangular member in buckling	$F_{tc}$	Ultimate tensile strength of solid metal control specimen
$d_1, d_2$	Cross-sectional dimension of the rectangular member in the plane of the Truss and perpendicular to the plane of the Truss, respectively	$F_{tp}$	Ultimate tensile strength of Metal Connector Plate
$d_e$	Effective depth of member for tension perpendicular to grain loads ( $c + y$ )	$F_u$	Ultimate tensile strength of steel
$d_{le}$	Distance from the outer edge of the chord to the outer edge of the Metal Connector Plates joining the two chord members	$F_v, F'_v$	Reference and adjusted shear design stress parallel to grain (horizontal shear)
$E, E'$	Reference and adjusted modulus of elasticity	$F_{vs}$	Allowable shear stress of the steel
$E_{min}, E'_{min}$	Reference and adjusted modulus of elasticity for stability calculations	$F_y$	Minimum yield strength of the steel
$F_\theta$	Allowable bearing design stress at an angle to grain	$F_{y,spec}$	Specified minimum steel yield strength
$F_b, F'_b$	Reference and adjusted design stress for bending	$F_{y,test}$	Average measured steel yield strength of test plates
$F_b^*$	Design stress for bending adjusted by modification factors	$f_b$	Actual bending stress
$F_{bE}$	Critical buckling design stress for bending members	$f_c$	Actual compression stress parallel to grain
		$f_{c\perp}$	Actual compression stress perpendicular to grain
		$f_t$	Actual tension stress parallel to grain
		$f_v$	Actual shear stress parallel to grain
		$G$	(1) Specific gravity (oven-dry basis) of wood



	specified for design (also shown as $G_{\text{specified}}$ ) or (2) tooth embedment gap (see Section 3.7.7.2.4)		(2) Gross length of Metal Connector Plates
$G_{\text{test}}$	Average measured specific gravity (oven-dry basis) of wood used in test joints	$L_u$	Unsupported length of bending member
$g$	Transverse center-to-center spacing or gauge of any two consecutive holes (see Section 5.4.1.2)	$L_w$	Actual length of Web member
$H_R$	Heel reduction factor	$M$	Actual bending moment
$h$	Height of equivalent rectangle (see Section 8.7.1.2)	$M_a$	Maximum allowable bending moment
$JSI$	Joint Stress Index, which is determined for each joint as the largest ratio of applied force to allowable design force	$N$	Minimum required number of Teeth per face
$K$	Effective length factor	$P$	(1) Total concentrated load or axial load or (2) force in Wood Member, for design of Truss joints
$K_b$	Load and span effect constant	$P'$	Resultant compressive force used for determination of minimum required Metal Connector Plate contact area
$K_{cr}$	Creep factor	$P_{\perp}$	Net force component perpendicular to grain
$K_f$	Column stability coefficient for bolted and nailed built-up columns	$P_c$	Axial compression force
$K_m$	Bending capacity modification factor	$P_{CR}$	Axial force in compression parallel to the grain of the chord to the right of the panel point
$\ell$	(1) Calculated shear length of the Metal Connector Plate oriented at an angle ( $\alpha$ ) to the joint or (2) distance measured from the centerline of the girder cross-section to the midpoint ( $1/2$ seat width) of the hanger where the point load is located, or the distance to the center of a structural member framing into the girder (i.e., jack)	$P_{CL}$	Axial force in compression parallel to the grain of the chord to the left of the panel point
$\ell_b$	Length of bearing	$P_{CW}$	Axial force in compression parallel to the grain of the Web
$l'$	Plate dimension parallel to the loading direction for Test Specimens used to develop lateral resistance strength of Metal Connector Plate Teeth	$P_{in}$	Compression force component of the Wood Member under investigation normal to the joint interface
$L$	(1) Nominal panel length of chords used in computing bending moment and buckling length or (2) length of solid metal control specimen	$P_{ip}$	Compression force component of the Wood Member under investigation parallel to the joint interface
$L'$	Effective buckling length of compression member	$P_s$	Force parallel to the joint across the shear plane
$L_e$	Effective span length for bending members	$P_{sp}$	Maximum shear force carried by the Metal Connector Plate
$L_p$	(1) Center to center spacing of purlins or	$P_t$	Axial tension force
		$P_{tc}$	Maximum tensile force carried by the solid metal control specimen
		$P_{tp}$	Maximum tensile force carried by the Metal Connector Plate

$P_{TW}$	Axial force in tension parallel to the grain of the Web		Metal Connector Plate unit adjusted per all applicable factors
$Q_R$	Strength ratio between matched sets of single pass full embedment roller pressed joints and hydraulic pressed joints, in accordance with Annex A.5.2	$V_{LR}^*$	Allowable lateral resistance value per Metal Connector Plate unit adjusted per all applicable factors except $C_q$
$R_G$	Adjustment factor for specific gravity of Test Specimens exceeding specified value (see Section 5.2.9.3)	$V_{LRAA}$	Allowable value for Metal Connector Plates loaded parallel to the grain with the plate axis (tooth slots) parallel to the load
$R_s$	Shear efficiency, $F_{sp}/F_{sc}$	$V_{LRAE}$	Allowable value for Metal Connector Plates loaded perpendicular to the grain with the plate axis (tooth slots) parallel to the load
$R_T$	Adjustment factor to account for steel thickness	$V_{LRA\theta}$	Allowable value for Metal Connector Plates loaded at an angle, $\theta$ , to the grain with the plate axis (tooth slots) parallel to the load
$R_t$	Tensile efficiency, $F_{tp}/F_{tc}$	$V_{LREA}$	Allowable value for Metal Connector Plates loaded parallel to the grain with the plate axis (tooth slots) perpendicular to the load
$R_i$	Reaction or load imposed by uniformly spaced members on a girder	$V_{LREE}$	Allowable value for Metal Connector Plates loaded perpendicular to the grain with the plate axis (tooth slots) perpendicular to the load
$R_Y$	Adjustment factor to account for steel yield	$V_{LRE\theta}$	Allowable value for Metal Connector Plates loaded at an angle, $\theta$ , to the grain with the plate axis (tooth slots) perpendicular to the load
$S$	Section modulus	$V_s$	Allowable design value in shear for a pair of metal connector plates
$s$	Longitudinal center-to-center spacing or pitch of any two consecutive holes (see Section 5.4.8.2)	$V_{s\parallel}$	Capacity of a pair of Metal Connector Plates to resist shear along the major axis
$T_G$	Applied torque to girder Truss	$V_{s\perp}$	Capacity of a pair of Metal Connector Plates to resist shear at 90° to the major axis
$T_1, T_2$	Components of tension force in steel of Truss plate across joint subject to bending (see Section 8.7.1.1)	$V_t$	Allowable design value in tension for a pair of Metal Connector Plates
$t$	Minimum specified steel thickness (also shown as $t_{spec}$ )	$V_{t\parallel}$	Tensile capacity of the Metal Connector Plate section where the load is applied parallel to the major axis
$t_1$	Base metal design thickness of the Metal Connector Plate, $(t - t_c) / 0.95$	$V_{t\perp}$	Tensile capacity of the Metal Connector Plate section where the load is applied at a 90° to the major axis
$t_c$	Coating thickness	$W$	Gross width of the solid metal control specimen
$t_{net}$	Net thickness, $(t - t_c)$		
$V$	Actual shear force		
$V'$	Maximum allowable shear force (see Section 7.3.7.3)		
$V_{LR}$	Lateral resistance value per Metal Connector Plate unit, based on a plate on each face		
$V_{LR}'$	Allowable lateral resistance design value per		

$W_p$	Gross Metal Connector Plate Width
$W'_p$	Maximum effective width of Metal Connector Plates for all panel point tension chord splices with Metal Connector Plates that extend past the chord member
$w$	Uniformly distributed load (constant or varying)
$X_{st}$	Combined shear/tension value for the effective horizontal dimension of a pair of Metal Connector Plates
$x$	(1) Offset of centerline of rectangular opening from centerline of Truss or (2) distance between splice and nearest panel point (see Section 8.7.1.1)
$x_{max}$	Distance from the inner edge of the chord to the inner edge of the Metal Connector Plate joining the chord-splice and extended past the chord member
$Y_{st}$	Combined shear/tension value for the effective vertical dimension of a pair of Metal Connector Plates
$y$	(1) Distance to the centerline of the extreme fastener from the centerline of the Wood Member or (2) Distance to neutral axis from edge of Wood Member with moment-induced compression
$z$	Distance from compression edge of lumber to compression edge of plate (see Section 8.7.1.1)
$\Delta_T$	Total deflection
$\Delta_{LT}$	Immediate deflection due to the long-term component of the design load (deflection due to a sustained load, typically dead load)
$\Delta_{ST}$	Deflection due to short term or normal component of the design load (deflection due to transient loads, typically live load)
$\alpha$	Angle between the load and the Metal Connector Plate Length (slot) direction (see Section 5.3.2 and Figures 5.3-2 through 5.3-5)
$\theta$	(1) Angle between the Top and Bottom Chords or (2) angle between the load and wood grain

## 1.6 DEFINITIONS

The following definitions apply in this Standard. See Chapter 2 of this Standard for additional definitions. For general definitions of terms used in the test methods in Chapter 5 of this Standard, and not given in Section 1.6, see *ASTM E631*.

**Bottom Chord** - Horizontal or inclined (e.g., scissors Truss) member that establishes the lower edge of a Truss, usually carrying combined tension and bending stresses. A Bottom Chord shall be permitted to consist of shorter spliced segments.

**Cantilever** – Extension of both chords of a Truss beyond its end support for a distance that is included in the defined span, exclusive of Overhang.

**Critical Slip** - When measured from the Metal Connector Plate to each active Wood Member, Critical Slip is 0.015 in. (0.38 mm); when measured from Wood Member to Wood Member, it is 0.030 in. (0.76 mm), except for AE and EE orientations, in which case it is 0.015 in. (0.38 mm).

**Edge Distance** - Distance from the edge of the Wood Member, measured perpendicular to the length of the Wood Member, in which Teeth are presumed to be ineffective for lateral resistance design purposes and in which Teeth are prohibited from being located for lateral resistance testing purposes. This distance shall be permitted to vary for different testing methods, but shall be consistent between the Test Specimens used to establish a lateral resistance design value and the design calculations in which that lateral resistance design value is used, except as permitted by Section 8.3.2.1.

**Effectiveness Ratio** - Ratio of the Metal Connector Plate ultimate strength (shear or tensile) to the matched solid metal control specimen ultimate strength.

**End Distance** - Distance from the end of the Wood Member, measured parallel to the length of the Wood Member, in which Teeth are presumed to be ineffective for lateral resistance design purposes and in which Teeth are prohibited from being located for lateral resistance testing purposes. This distance shall be permitted to vary for different testing methods, but shall be consistent between the Test Specimens used to establish a lateral resistance design value and the design calculations in which that lateral resistance design value is used, except as permitted by Section 8.3.2.1.

**Gross Area Method** - Lateral resistance testing and design calculation in which the End and Edge Distances are zero.

**Joint QC Detail** - Graphical detail of a Truss joint that shows positioning tolerances calculated by the Truss Designer for any particular joint of a Truss selected for Truss inspection per the requirements of Chapter 3 of this Standard.

**Keeper Nails** – Nails driven through the Metal Connector Plate, during Truss fabrication, to hold its location on the Wood Members before pressing.

**Metal Connector Plate** - Metal plate used to connect coplanar Wood Members, so as to transmit forces from one Wood Member to one or more other Wood Members, and connected to such Wood Members using either integral Teeth formed from the metal plate and subsequently embedded into the wood, or separately applied driven fasteners such as nails. Also referred to as plate, Truss plate, metal plate, metal-plate connector, and nail plate.

**Metal Connector Plate Length** - Dimension of the Metal Connector Plate parallel to the longitudinal axis of the face coil from which the Teeth were stamped during Metal Connector Plate fabrication normally the dimension parallel to the length of the slots.

**Metal Connector Plate Width** - Dimension of the Metal Connector Plate perpendicular to the longitudinal axis of the face coil from which the Teeth were stamped during Metal Connector Plate fabrication normally the dimension perpendicular to the length of the slots.

**Nail Hole** - Round perforation in a Metal Connector Plate through which a nail can be driven to fasten a Metal Connector Plate to a Wood Member and to transmit shear loads; providing a predetermined location for appropriately locating the nail to be driven.

**Narrow Face** - Face or surface of a Wood Member with a dimension less than or equal to 2 in. (50.8 mm).

**Overhang** - Extension of the Top Chord beyond the Bottom Chord or the Bottom Chord beyond the Top Chord of a Truss, exclusive of Cantilever.

**Sample Block** - Sample cut from the Wood Member for the purpose of determining the specific gravity and/or moisture content of the Wood Member used in testing.

**Net Area Method** - Lateral resistance testing and design calculation in which the End Distance is  $\frac{1}{2}$  in. (13 mm) and the Edge Distance is  $\frac{1}{4}$  in. (6 mm). (Note: For design purposes using lateral resistance design values in units of force per unit area, these distances shall be adjusted to match the distances tributary to the Teeth that are removed in the given distances.)

**Sidesway** - Top of a column is relatively free to displace laterally with respect to the bottom of the column and its lateral displacement is resisted primarily by the flexural rigidity of the column. The opposite condition (without Sidesway) occurs when the ends of the column are prevented from moving relative to each other by a much stiffer restraint, such as a trussed frame (where openings between members consist solely of triangles) connected to both ends of the compression member, or other structure.

**Solid Metal Control Sample** - Solid plate sample of the same material as the Metal Connector Plate of dimensions large enough so as to fabricate solid metal control specimens in accordance with *ASTM E8*; without integral Teeth. It is used to determine the mechanical properties of the metal.

**Species Combination** - Grouping of several species into a single category (e.g., Spruce-Pine-Fir).

**Structural Composite Lumber** - See *ASTM D5456*.

**Teeth** - Integral metal projections of the Metal Connector Plate formed to be more or less perpendicular to the face of the Metal Connector Plate during the stamping process. Also called prongs, barbs, plugs, nails, etc., but henceforth they will be termed Teeth.

**Test Specimen** - Connection to be tested; lateral strength and tensile strength Test Specimens are fabricated by joining two Wood Members together with two Metal Connector Plates, and the shear strength Test Specimen is fabricated by joining three Wood Members together with four Metal Connector Plates.

**Top Chord** - Horizontal or inclined member that establishes the upper edge of the Truss. A Top Chord shall be permitted to consist of shorter spliced segments.

**Webs** - Wood Members that join the Top and Bottom Chords that form the triangular patterns that give Truss action, usually carrying tension or compression stresses.

**Wood Member** - Piece of lumber, from the Species Combination or Structural Composite Lumber evaluated, which is to be joined to a like piece of lumber, and which contains clear wood in the area in which the Metal Connector Plate is embedded (see Section 5.2.4.3).

## 1.7 CONVERSION FACTORS

1 in	=	25.40 mm
1 ft	=	0.3048 m
1 lb	=	0.4536 kg
1 lbf	=	4.448 N
1 ksi	=	6.894 MPa
1 psf	=	47.88 Pa
1 pli	=	0.1751 N/mm
1 plf	=	14.59 N/m

Single User Read-Only Document

## CHAPTER 2

# STANDARD RESPONSIBILITIES IN THE DESIGN AND APPLICATION OF METAL-PLATE-CONNECTED WOOD TRUSSES

### 2.1 GENERAL PURPOSES

The purpose of this Chapter of the Standard is to define and draw attention to the Responsibilities of the Owner, Building Designer, Truss Manufacturer, and Truss Designer, with respect to the application of Trusses in the construction of a Building.

### 2.2 DEFINITIONS

**BCSI:** *Guide to Good Practice for Handling, Installing, Restraining & Bracing of Metal Plate Connected Wood Trusses* jointly produced by the *Structural Building Components Association* and the *Truss Plate Institute*.

**BCSI-B1:** *Guide for Handling, Installing, Restraining & Bracing of Trusses* of the Building Component Safety Information (BCSI).

**BCSI-B2:** *Truss Installation & Temporary Restraint/Bracing* of the Building Component Safety Information (BCSI).

**BCSI-B3:** *Permanent Restraint/Bracing of Chords & Web Members* of the Building Component Safety Information (BCSI).

**BCSI-B7:** *Guide for Handling, Installing & Bracing of 3x2 and 4x2 Parallel Chord Trusses* of the Building Component Safety Information (BCSI).

**BCSI-B10:** *Post Frame Truss Installation, Restraint & Bracing* of the Building Component Safety Information (BCSI).

**Building:** Structure used or intended for supporting or sheltering any use or occupancy.

**Building Code:** As it applies to a Building, any set of standards set forth and enforced by a Jurisdiction for the protection of public safety.

**Building Designer:** Owner of the Building or the Person that contracts with the Owner for the design of the Building Structural System and/or who is responsible for the preparation of the Construction Documents. When mandated by the Legal Requirements, the Building Designer shall be a Registered Design Professional.

**Building Official:** Officer or other designated authority charged with the administration and enforcement of the Building Code, or a duly authorized representative.

**Building Permit:** Certificate of permission issued by a Jurisdiction to an Owner to construct, enlarge, or alter a Building.

**Building Structural System:** Completed combination of Structural Elements, Trusses, connections and other systems, which serve to transfer the Building's self-weight and the specified loads to the foundation or ground.

**Construction Documents:** Written, graphic and pictorial documents prepared or assembled for describing the design (including the Building Structural System), location and physical characteristics of the elements of a Building necessary to obtain a Building Permit and construct a Building. Where required by the statutes of the jurisdiction in which the project is to be constructed, the Construction Documents or parts of the Construction Documents, shall be prepared by a Registered Design Professional.

**Contract:** Legally recognized agreement between two parties.

**Contractor:** Owner of a Building, or the Person who contracts with the Owner, who constructs the Building in accordance with the Construction Documents and the Truss Submittal Package. The term "Contractor" shall include those subcontractors who have a direct Contract with the Contractor to construct all or a portion of the construction.

**Cover/Truss Index Sheet:** Sheet that is signed and sealed, where required by the Legal Requirements, by the Truss Designer, and depending on the Legal Requirements shall be permitted to contain the following information: (1) Identification of the Building, including Building name and address, lot, block, subdivision, and city or county; (2) Identification of Construction Documents by drawing number(s) with revision date; (3) specified Building Code; (4) computer program used; (5) roof dead and live loads; (6) floor dead and live loads; (7) wind load criteria from a specifically defined code (e.g., ASCE 7) and any other design loads (such as ponding, mechanical loads, etc.); (8) name, address and license

number of Building Designer, if known; (9) a listing of the individual identification numbers and dates of each Truss Design Drawing referenced by the Cover/Truss Index Sheet; and (10) name, address, date of Cover/Truss Index Sheet and license number of Truss Designer.

**Deferred Submittal:** Those portions of the design that are not completed at the time of the application for the Building Permit and that are to be submitted to the Building Official within a specified period in accordance with the Legal Requirements.

**Diagonal Bracing:** Within a Truss system, structural member(s) installed along a portion of a Top Chord, Bottom Chord, or Web plane, at approximately 45 degrees to a Lateral Restraint member to provide a load path for the Lateral Restraint (See *BCSI-B1*, *BCSI-B2*, *BCSI-B3*, *BCSI-B7*, and *BCSI-B10*).

**Jurisdiction:** Governmental unit that is responsible for adopting and enforcing the Building Code.

**Lateral Restraint:** Also known as continuous lateral brace or CLB. A structural member installed at right angles to a chord or Web member of a Truss to reduce the laterally unsupported length of the Truss member (See *BCSI-B1*, *BCSI-B2*, *BCSI-B3*, *BCSI-B7*, and *BCSI-B10*).

**Legal Requirements:** Any applicable provisions of all statutes, laws, rules, regulations, ordinances, codes, or orders of the governing Jurisdiction.

**Owner:** Person having a legal or equitable interest in the property upon which a Building is to be constructed, and: (1) either prepares, or retains the Building Designer or Registered Design Professional to prepare the Construction Documents; and (2) either constructs, or retains the Contractor to construct the Building.

**Permanent Building Stability Bracing:** Lateral force resisting system for the Building that resists forces from gravity, wind, seismic and/or other loads.

**Permanent Individual Truss Member Restraint:** Restraint that is used to prevent local buckling of an individual Truss chord or Web member due to the axial forces in the individual Truss member (See *BCSI-B2* and *BCSI-B3*).

**Person:** Individual or organization that may exist in accordance with the Legal Requirements. (The term “Person” as used in this Chapter 2 may either appear as “Person” or “person.”)

**Registered Design Professional:** Architect or engineer, who is licensed to practice their respective design profession as defined by the Legal Requirements of the Jurisdiction in which the Building is to be constructed.

**Special Inspector:** A qualified Person approved by the Building Official as having the competence necessary to perform special inspections.

**Standard:** *National Design Standard for Metal Plate Connected Wood Truss Construction (ANSI/TPI 1)*.

**Structural Element:** Single structural member (other than a Truss) that is specified in the Construction Documents.

**Temporary Installation Restraint/Bracing:** Lateral Restraint and Diagonal Bracing installed during construction for the purposes of holding Trusses in their proper location, plumb and in plane, until Permanent Individual Truss Member Restraint, Diagonal Bracing and Permanent Building Stability Bracing are completely installed (See *BCSI-B1*, *BCSI-B2*, *BCSI-B3*, *BCSI-B7*, and *BCSI-B10*).

**Truss:** Individual metal-plate-connected wood component manufactured for the construction of a Building.

**Truss Design Drawing:** Written, graphic and pictorial depiction of an individual Truss that includes the information required in Sections 2.3.5.5.

**Truss Designer:** Person responsible for the preparation of the Truss Design Drawings.

**Truss Manufacturer:** Person engaged in the fabrication of Trusses.

**Truss Placement Diagram:** Illustration identifying the assumed location of each Truss.

**Truss Submittal Package:** Package consisting of each individual Truss Design Drawing, and, as applicable, the Truss Placement Diagram, the Cover/Truss Index Sheet, Lateral Restraint and Diagonal Bracing details designed in accordance with generally accepted engineering practice, applicable *BCSI*-defined Lateral Restraint and Diagonal Bracing details, and any other structural details germane to the Trusses.

## 2.3 RESPONSIBILITIES

Where the Legal Requirements mandate a Registered Design Professional for buildings, the Building Designer and the Truss Designer shall be Registered Design Professionals.

### 2.3.1 Requirements of the Owner.

#### 2.3.1.1 Building Permit.

Where required by Legal Requirements, including the Building Code, the Owner shall obtain a Building Permit.

If special inspections or structural observations related to Trusses are required as part of the Construction Documents and/or permitting process, these requirements shall be communicated in writing to the Contractor or Truss Manufacturer as appropriate.

#### 2.3.1.2 Registered Design Professional Designation.

The Owner shall engage and designate on the Building Permit application the Registered Design Professional for the Building, if the Building Designer is required to be a Registered Design Professional.

#### 2.3.1.3 Engagement with the Building Designer.

The Owner shall engage a Building Designer to prepare the Construction Documents and review the Truss Submittal Package.

The Truss Manufacturer and Truss Designer shall be notified in writing by either the Owner or Contractor if the Building Designer is changed or is unable to continue to perform their duties.

In the absence of an independent Building Designer, the Owner shall assume the role of Building Designer.

#### 2.3.1.4 Engagement with the Contractor.

The Owner shall engage a Contractor to store, handle and install the Trusses for the Building, in compliance with any and all Legal Requirements.

#### 2.3.1.5 Review and Coordinate Submittal Packages.

The Owner or Owner's representative shall be responsible for ensuring that the requirement of Section 2.3.4.2 is accomplished.

#### 2.3.1.6 Long Span Truss Requirements.

##### 2.3.1.6.1 Restraint/Bracing Design.

In all cases where a Truss clear span is 60 ft. (18 m) or greater, the Owner shall contract with any Registered Design Professional for the design of the Temporary Installation Restraint/Bracing and the Permanent Individual

Truss Member Restraint and Diagonal Bracing.

##### 2.3.1.6.2 Special Inspection.

In all cases where a Truss clear span is 60 ft. (18 m) or greater, the Owner shall contract with a Special Inspector to perform special inspections. Special Inspections shall assure that the Trusses, including the Temporary Installation Restraint/Bracing and the Permanent Individual Truss Member Restraint and Diagonal Bracing are installed in accordance with the approved Construction Documents and the approved Truss Submittal Package.

##### 2.3.1.7 Responsibility Exemptions.

The Owner is responsible for items listed in Section 2.3.1, and is not responsible for the requirements of other parties specified outside of Section 2.3.1.

### 2.3.2 Requirements of the Building Designer.

#### 2.3.2.1 Construction Documents.

The Construction Documents shall be prepared by the Building Designer and shall be of sufficient clarity to indicate the location, nature and extent of the work proposed, and show in detail that such documents conform to the Legal Requirements, including the Building Code.

#### 2.3.2.2 Deferred Submittals.

The Building Designer shall list the Deferred Submittals on the Construction Documents. The Building Designer shall review Deferred Submittals in accordance with Section 2.3.2.3.

#### 2.3.2.3 Review Submittal Packages.

The Building Designer shall review the Truss Submittal Package for compatibility with the Building design. All such submittals shall include a notation indicating that they have been reviewed and whether or not they have been found to be in general conformance with the design of the Building.

#### 2.3.2.4 Required Information in the Construction Documents.

The Building Designer, through the Construction Documents, shall provide information sufficiently accurate and reliable to be used for facilitating the supply of the Structural Elements and other information for developing the design of the Trusses for the Building, and shall provide the following:

- (a) All Truss and Structural Element orientations and locations.
- (b) Information to fully determine all Truss profiles.
- (c) All Structural Element and Truss support loca-



tions and bearing conditions (including the allowable bearing stress).

- (d) The location, direction, and magnitude of all dead, live, and lateral loads applicable to each Truss including, but not limited to, loads attributable to: roof, floor, partition, mechanical, fire sprinkler, attic storage, rain and ponding, wind, snow (including snow drift and unbalanced snow), seismic; and any other loads on the Truss;
- (e) All anchorage designs and connections to the Structural Elements and the Permanent Building Stability Bracing required to resist uplift, gravity, and lateral loads.
- (f) Truss-to-Structural Element connections, but not Truss-to-Truss connections.
- (g) Criteria related to serviceability issues including:
  - (1) Allowable vertical, horizontal or other required deflection criteria.
  - (2) Any dead load, live load, and in-service creep deflection criteria for roofs subject to ponding loads.
  - (3) Any Truss camber requirements.
  - (4) Any differential deflection criteria from Truss-to-Truss or Truss-to-adjacent Structural Element.
 

*User (non-mandatory) note:* See Commentary section §2.3.2.4(h)(4) regarding methods to address differential deflection.
  - (5) Any deflection and vibration criteria for floor Trusses including:
    - (i) Any strongback bridging requirements.
    - (ii) Any dead load, live load, and in-service creep deflection criteria for floor Trusses supporting stone or ceramic tile finishes.
  - (6) Moisture, temperature, corrosive chemicals and gases expected to result in:
    - (i) Wood moisture content exceeding 19 percent,

- (ii) Sustained temperatures exceeding 150 degrees F, and/or
- (iii) Corrosion potential from wood preservatives or other sources that can be detrimental to Trusses.

### 2.3.2.5 Responsibility Exemptions.

The Building Designer is responsible for items listed in Section 2.3.2, and is not responsible for the requirements of other parties specified outside of Section 2.3.2.

## 2.3.3 Requirements for the Permanent Member Restraint/Bracing of Truss Systems.

### 2.3.3.1 Method of Restraint.

The method of Permanent Individual Truss Member Restraint/Bracing and the method of anchoring or restraining to prevent lateral movement of all Truss members acting together as a system shall be accomplished by:

#### 2.3.3.1.1 Standard Industry Details.

Standard industry Lateral Restraint and Diagonal Bracing details in accordance with *BCSI-B3: Permanent Restraint/Bracing of Chords & Web Members* and/or *BCSI-B7: Temporary & Permanent Restraint/Bracing for Parallel Chord Trusses* of the Building Component Safety Information (*BCSI*).

#### 2.3.3.1.2 Substitution with Reinforcement.

Permanent Individual Truss Member Restraint shall be permitted to be replaced with reinforcement designed to prevent buckling (e.g., buckling reinforcement by T-reinforcement or L-reinforcement, proprietary reinforcement, etc.).

#### 2.3.3.1.3 Project Specific Design.

A project specific Truss member permanent Lateral Restraint/bracing design for the roof or floor Framing Structural System shall be permitted to be specified by the Building Designer or any Registered Design Professional.

### 2.3.3.2 Absence of Truss Restraint/Bracing Method or Details.

If a specific Truss member permanent bracing design for the roof or floor Framing Structural System is not provided by the Owner, Building Designer or any Registered Design Professional, the method of Permanent Individual Truss Member Restraint and Diagonal Bracing for the Truss Top Chord, Bottom Chord, and Web members shall be in accordance with *BCSI-B3* or *BCSI-B7*.

### 2.3.3.3 Trusses Spanning 60 Feet (18 m) or Greater.

For Trusses with clear spans 60 ft. (18 m) or greater, see Section 2.3.1.6.

### 2.3.4 Requirements of the Contractor.

#### 2.3.4.1 Information Provided to the Truss Manufacturer.

The Contractor shall provide to the Truss Manufacturer a copy of all Construction Documents pertinent to the Building Structural System and the design of the Trusses (i.e., framing plans, specifications, details, structural notes), and the name of the Building Designer if not noted on the Construction Documents.

Amended Construction Documents upon approval through the plan review/permitting process shall be immediately communicated to the Truss Manufacturer.

#### 2.3.4.2 Information Provided to the Building Designer.

The Contractor, after reviewing and/or approving the Truss Submittal Package, shall forward the Truss Submittal Package to the Building Designer for review.

#### 2.3.4.3 Truss Submittal Package Review.

The Contractor shall not proceed with the Truss installation until the Truss Submittal Package has been reviewed by the Building Designer.

#### 2.3.4.4 Means and Methods.

The Contractor is responsible for the construction means, methods, techniques, sequences, procedures, programs, and safety in connection with the receipt, storage, handling, installation, restraining, and bracing of the Trusses.

#### 2.3.4.5 Truss Installation.

The Contractor shall ensure that the Building support conditions are of sufficient strength and stability to accommodate the loads applied during the Truss installation process. Truss installation shall comply with installation tolerances shown in *BCSI-B1*. Temporary Installation Restraint/Bracing for the Truss system and the permanent Truss system Lateral Restraint and Diagonal Bracing for the completed Building and any other construction work related directly or indirectly to the Trusses shall be installed by the Contractor in accordance with:

- (a) The Construction Documents, and/or
- (b) The Truss Submittal Package.

For Trusses clear spanning 60 ft. (18 m) or greater, see Section 2.3.1.6.

#### 2.3.4.6 Pre-Installation Check.

The Contractor shall examine the Trusses delivered to the job site for:

- (a) Dislodged or missing connectors,
- (b) Cracked, dislodged or broken members, or
- (c) Any other damage that can impair the structural integrity of the Truss.

#### 2.3.4.7 Post-Installation Check.

The Contractor shall examine the Trusses after they are erected and installed for:

- (a) Dislodged or missing connectors,
- (b) Cracked, dislodged or broken members, or
- (c) Any other damage that can impair the structural integrity of the Truss.

#### 2.3.4.8 Truss Damage Discovery.

In the event that damage to a Truss is discovered the Contractor shall:

- (a) Ensure that the Truss not be erected, or
- (b) That any area within the Building supported by any such Truss already erected shall be appropriately shored or supported to prevent further damage from occurring and shall remain clear and free of any load imposed by people, plumbing, electrical, mechanical, bridging, bracing, etc. until field repairs have been properly completed per Section 2.3.4.9.

#### 2.3.4.9 Truss Damage Responsibilities.

In the event of damage, the Contractor shall:

- (a) Contact the Truss Manufacturer and Building Designer to determine an adequate field repair, and
- (b) Construct the field repair in accordance with the written instructions and details provided by the Truss Manufacturer, Building Designer, and/or any Registered Design Professional.

#### 2.3.4.10 Responsibility Exemptions.

The Contractor is responsible for items listed in Section 2.3.4, and is not responsible for the requirements of other parties specified outside of Section 2.3.4.

### 2.3.5 Requirements of the Truss Designer.

#### 2.3.5.1 Preparation of Truss Design Drawings.

The Truss Designer is responsible for the preparation of the Truss Design Drawings based on the Truss design

criteria and requirements set forth in the Construction Documents or as otherwise set forth in writing by the Building Designer as supplied to the Truss Designer by the Contractor through the Truss Manufacturer.

### 2.3.5.2 Single Truss Component Design.

The Truss Designer shall be responsible for the design, in accordance with this Standard, of each singular Truss depicted on each Truss Design Drawing.

### 2.3.5.3 Truss Design Drawing Seal and Signature.

Where the Legal Requirements mandate a Registered Design Professional for buildings, each individual Truss Design Drawing shall bear the seal and signature of the Truss Designer.

**Exception:** When a Cover/Truss Index Sheet is used, it is the only document required to be signed and sealed by the Truss Designer.

### 2.3.5.4 Truss Placement Diagram.

When the Truss Placement Diagram serves only as a guide for Truss installation, it does not require the seal of the Truss Designer.

### 2.3.5.5 Information on Truss Design Drawings.

Truss Design Drawings shall include, at a minimum, the information specified below:

- (a) Building Code used for design, unless specified on Cover/Truss Index Sheet.
- (b) Slope or depth, span and spacing.
- (c) Location of all joints and support locations.
- (d) Number of plies if greater than one.
- (e) Required bearing widths.
- (f) Design loads as applicable, including:
  - (1) Top Chord live load (for roof Trusses, this shall be the controlling case of live, snow or rain load);
  - (2) Top Chord dead load;
  - (3) Bottom Chord live load;
  - (4) Bottom Chord dead load;
  - (5) Additional loads and locations;

(6) Environmental load design criteria (wind speed, snow, rain, seismic, and all applicable factors as required to calculate the Truss loads); and

(7) Other lateral loads, including drag strut loads.

(g) Adjustments to Wood Member and Metal Connector Plate design values for conditions of use.

(h) Maximum reaction force and direction, including maximum uplift reaction forces where applicable.

(i) Metal Connector Plate type, manufacturer, size, and thickness or gauge, and the dimensioned location of each Metal Connector Plate except where symmetrically located relative to the joint interface.

(j) Size, species and grade for each Wood Member.

(k) Truss-to-Truss connection and Truss field assembly requirements.

(l) Calculated span to deflection ratio and/or maximum vertical and horizontal deflection for live load and for live plus dead load and  $K_{CR}$  as applicable per Section 7.6.

(m) Maximum axial tension and compression forces in the Truss members.

(n) Fabrication tolerance per Section 6.4.10.

(o) Required Permanent Individual Truss Member Restraint location.

(p) Truss Designer

### 2.3.5.6 Responsibility Exemptions.

The Truss Designer is responsible for items listed in Section 2.3.5, and is not responsible for the requirements of other parties specified outside of Section 2.3.5.

## 2.3.6 Requirements of the Truss Manufacturer.

### 2.3.6.1 Truss Design Criteria and Requirements.

The Truss Manufacturer shall obtain the Truss design criteria and requirements from the Construction Documents.

**2.3.6.2 Communication to Truss Designer.**

The Truss Manufacturer shall communicate the Truss design criteria and requirements to the Truss Designer.

**2.3.6.3 Alternate Truss Designs.**

If an alternative or partial set of Truss design(s) is proposed by either the Truss Manufacturer or the Truss Designer, such alternative set of design(s) shall be sent to and reviewed by the Building Designer for the Building prior to manufacturing. Where the Legal Requirements mandate a Registered Design Professional for buildings, these alternative set of design(s) do not require the seal of the Truss Designer until accepted by the Building Designer, whereupon these alternative Truss Design Drawings shall be sealed by the Truss Designer.

**2.3.6.4 Truss Placement Diagram.**

Where required by the Construction Documents or Contract, the Truss Manufacturer shall prepare the Truss Placement Diagram that identifies the assumed location for each individually designated Truss and references the corresponding Truss Design Drawing. The Truss Placement Diagram shall be permitted to include identifying marks for other products including Structural Elements, so that they can be more easily identified by the Contractor during field erection. When the Truss Placement Diagram serves only as a guide for Truss installation and requires no engineering input, it does not require the seal of any Registered Design Professional including in cases where the Legal Requirements mandate a Registered Design Professional for buildings.

**2.3.6.5 Required Documents.**

The Truss Manufacturer shall supply to the Contractor the Truss Submittal Package, including the Truss Design Drawings, a Truss Placement Diagram, if required by the Construction Documents or Contract, and the required Permanent Individual Truss Member Restraint location and the method to be used per Section 2.3.3.

**2.3.6.6 Special Application Conditions.**

The Truss Manufacturer shall be allowed to provide detail drawings to the Contractor to document special application conditions.

**2.3.6.7 Truss Submittal Packages.**

Where required by the Construction Documents or Contract, Legal Requirements or the Building Official, the Truss Manufacturer shall provide the appropriate Truss Submittal Package to one or more of the following: Building Official; Building Designer and/or Contractor for review and/or approval per Section 2.3.4.2.

**2.3.6.8 Reliance on Construction Documents.**

The Truss Manufacturer shall be permitted to rely on the accuracy and completeness of information furnished in the Construction Documents or otherwise furnished in writing by the Building Designer and/or Contractor.

**2.3.6.9 Fabrication Tolerance.**

The Truss Manufacturer shall determine the value for the fabrication tolerance to be used in the design of the Trusses (see Section 6.4.10).

**2.3.6.10 Manufacturer Quality Criteria.**

The Truss Manufacturer shall manufacture the Trusses in accordance with the final Truss Design Drawings, using the quality criteria required by this Standard unless more stringent quality criteria is provided by the Owner in writing or through the Construction Documents.

**2.3.6.11 In-Plant Truss Inspections.**

Truss inspections, as required by the Jurisdiction, shall be performed at the manufacturer's facility using the manufacturer's In-Plant Quality Assurance Program monitored by an inspection agency approved by the Jurisdiction, and shall satisfy any Quality Control/quality assurance requirements for the Trusses, and shall satisfy any designated in-plant special inspection requirements for the Trusses.

**2.3.6.12 Responsibility Exemptions.**

The Truss Manufacturer is responsible for items listed in Section 2.3.6, and is not responsible for the requirements of other parties specified outside of Section 2.3.6.

**2.4 CONTRACTS****2.4.1 Defer to Construction Documents.**

This Chapter of the Standard is not intended to take precedence over the Construction Documents, where a Contract between parties incorporates by reference the Construction Documents, and therefore the Construction Documents shall apply as between the parties to the Contract.

**2.4.2 Defer to Contract.**

This Chapter of the Standard is not intended to take precedence over a Contract as a Contract shall be permitted to contain provisions that take precedence over the Standard and/or the Construction Documents. A party shall not exclude in a Contract a responsibility established by this Standard or the Construction Documents unless that responsibility is assigned to a qualified party and that party agrees to that assignment.

Any changes made to the Construction Documents by Contract shall be submitted, reviewed and approved by the Building Official.

#### **2.4.3 Incorporation into Contract.**

A Contract shall be permitted to incorporate this Chapter of the Standard to establish the Responsibilities of the parties to such Contract.

Single User Read-Only Document

## CHAPTER 3

# QUALITY CRITERIA FOR THE MANUFACTURE OF METAL-PLATE-CONNECTED WOOD TRUSSES

### 3.1 GENERAL

#### 3.1.1 Scope.

Chapter 3 of this Standard is the quality standard for the manufacturing processes of metal-plate-connected wood Trusses, and shall be used in conjunction with a manufacturing quality assurance procedure and a Truss design. These provisions shall be included in the In-Plant Quality Assurance Program of each Truss Manufacturer.

#### 3.1.2 Requirements.

Metal-plate-connected wood Trusses shall meet the minimum manufacturing quality requirements specified in Chapter 3 of this Standard, so that design assumptions are met.

#### 3.1.3 Documentation.

Truss Manufacturers and inspection agencies shall establish methods that document the application of these quality assurance procedures throughout the manufacturing process. The Truss Manufacturer's methods shall be subject to periodic audit for compliance with the requirements of this Standard by an approved inspection agency per Section R110 Inspections of the *International Residential Code* / Section 110 Inspections of the *International Building Code*, where required by local authorities having Jurisdiction, or other means.

#### 3.1.4 Non-Conforming Inspections.

Manufacturing inaccuracies exceeding the allowable tolerances described within Chapter 3 are acceptable upon approval and follow-up documentation by a Truss Designer as defined in Chapter 2 of this Standard. Any necessary repair authorization shall be prepared by a Truss Designer.

### 3.2 IN-PLANT QUALITY ASSURANCE PROGRAM

#### 3.2.1 In-Plant Quality Control Manual.

An in-plant quality control manual shall be maintained for each Truss manufacturing facility, which will include the requirements for daily quality control and any audits that will be performed. At a minimum, the in-plant quality control manual shall contain:

- (a) Either a production flowchart or a description of the manufacturing process;

- (b) Manufacturer's organizational chart, a description of the duties and Responsibilities assigned to key positions in the quality program;
- (c) Quality control procedures, including sampling criteria and how manufacturing processes are monitored to ensure that the product is consistently manufactured within the allowable tolerances; and
- (d) A document retention policy.

#### 3.2.2 Inspection Frequency.

At a minimum, three Trusses per week per operational set-up location per shift as outlined in the in-plant quality control manual shall be inspected and recorded for in-plant audits.

#### 3.2.3 Inspection Sampling.

A random representative sampling of Trusses shall be chosen for inspection, either off the production line after all pressing operations are completed, or from finished goods storage.

#### 3.2.4 Inspection Procedure.

For Trusses chosen for inspection, the joint inspection procedures of Section 3.7 shall be used.

### 3.3 TRUSS DESIGN

#### 3.3.1 Truss Design Drawing.

A Truss Design Drawing shall be provided for every Truss, prior to manufacture and inspection. When the Truss Design Drawing specifies quality criteria that conflict with Chapter 3, the Truss Design Drawing shall prevail.

#### 3.3.2 Fabrication Tolerance.

All Truss joints shall be designed using a fabrication tolerance specified by the Truss Manufacturer. The fabrication tolerance correlates to the quality control factor,  $C_q$ , as defined in Section 6.4.10.

#### 3.3.3 Roller Press Value Reduction.

Joint QC Details for manufacturing lines utilizing single pass, full embedment rollers shall indicate the minimum permitted roller diameter resulting from  $Q_r$  per Section 5.2.5.

### 3.4 LUMBER

#### 3.4.1 Lumber Specifications.

Truss lumber shall be the size, species and grade specified on the Truss Design Drawing.

#### 3.4.2 Lumber Substitutions.

Truss lumber of a different grade shall be permitted if the substitute grade meets or exceeds the specified grade for each of the following engineering design properties:

- (a) Reference design value for bending ( $F_b$ );
- (b) Reference design value for tension ( $F_t$ );
- (c) Reference design value for compression parallel to grain ( $F_c$ );
- (d) Reference design value for compression perpendicular to grain ( $F_{c\perp}$ );
- (e) Reference design value for shear ( $F_v$ );
- (f) Specific gravity (G);
- (g) Reference modulus of elasticity (E); and
- (h) Reference modulus of elasticity for stability calculations ( $E_{min}$ ).

Any substitution of a specified Lumber grade not meeting the above requirements, or any substitution of a specified lumber grade to Structural Composite Lumber products shall require the review and approval of a Truss Designer.

#### 3.4.3 Lumber Identification.

Prior to cross-cutting, lumber shall be identified by the grade mark or the certificate of inspection issued by a lumber inspection agency accredited by the Board of Review of the American Lumber Standard Committee.

#### 3.4.4 Preservative Treatment Identification.

Preservative treated lumber shall be identified by the quality mark of, or a certificate of inspection from, an approved inspection agency and shall be identified by a label affixed to the package (see also Section 6.4.9).

#### 3.4.5 Fire Retardant Identification.

Lumber impregnated with fire retardant chemicals shall be identified by the quality mark of, or a certificate of inspection from, an approved inspection agency and shall be identified by a label affixed to the package (see also Section 6.4.9).

#### 3.4.6 Use of Finger-Jointed Lumber.

Structural finger-jointed lumber shall be permitted to be used interchangeably with solid-sawn members of the same grade and species if the finger joints are manufactured with an adhesive meeting the requirements of *ASTM D2559* and also meeting, for trusses to be used in fire-resistive construction, the high temperature performance requirements of the American Lumber Standard Committee. Structural finger-jointed lumber shall be identified by the grade mark of, or certificate of inspection from, a lumber grading or inspection agency that has been approved by an agency accredited by the Board of Review of the American Lumber Standard Committee. The grade mark and certification of inspection for structural finger-jointed lumber shall indicate that joint integrity is subject to qualification and quality control. Finger-jointed lumber marked "STUD USE ONLY" or "VERTICAL USE ONLY" shall not be used in metal-plate-connected wood Trusses. Finger-jointed lumber marked "Non-Heat-Resistant" or "NON-HRA" shall not be used in metal-plate-connected wood trusses to be used in fire-resistive construction.

#### 3.4.7 Lumber Splits.

Splits in any Wood Member caused by Metal Connector Plate Teeth or the manufacturing process shall not exceed those permitted in the grade and species of lumber used.

### 3.5 ASSEMBLY

#### 3.5.1 General.

Trusses shall be manufactured using cutting, jiggling, and pressing equipment. The location of Top and Bottom Chords, Webs, and joints shall be as specified on the Truss Design Drawing.

**Table 3.5-1 In-Plant Manufacturing Tolerances for Finished Truss Units.**

	Truss-to-Truss Variance Dimension of Identical Trusses	Variance from Design Dimensions
Length <sup>1</sup> of Finished Truss Unit	1/2 inch	3/4 inch
Height <sup>2</sup> of Finished Truss Unit	1/4 inch	1/2 inch

1. Length for manufacturing tolerance purposes, is the overall length of the Truss unit, excluding overhangs or extensions.
2. Height, for manufacturing tolerance purposes, is the overall height of the Truss unit measured at joints, excluding projections above the Top Chord and below the Bottom Chord, overhangs and extensions.

**3.5.2 Wood Members.**

Members shall be cut in accordance with the Truss Design Drawing.

**3.5.3 Height and Length.**

Truss height and length dimensions that vary from the Truss Design Drawing shall not exceed the tolerances shown in Table 3.5-1.

**3.6 PLATING OF JOINTS**

**3.6.1 Storage and Care.**

Metal Connector Plates shall be protected from damage during storage and shall be in an undamaged condition when used in the manufacture of wood Trusses.

**3.6.2 Specifications.**

Metal Connector Plates shall be of the gauge, type, manufacturer and size specified by the Truss Designer.

**3.6.3 Substitutions.**

A Metal Connector Plate with larger dimensions in one or both directions, but of the same type and gauge specified on the Truss Design Drawing, shall be an acceptable substitution provided the requirements of Section 3.6.5 are met. Overplating shall not be considered as a correc-

tive measure for joints not meeting the gap tolerances of Section 3.7.6 unless approved by a Truss Designer.

**3.6.4 Installation.**

Unless otherwise specified by the Truss Designer, Metal Connector Plates shall be installed on both faces of the Truss at each joint, and positioned in accordance with the Truss Design Drawing. All Trusses assembled using a single-pass full embedment roller press shall be designated on the Joint QC Detail as being for no less than the given diameter of roller press. Acceptable tolerances for plating are specified in Section 3.7.

**3.6.5 Plate Position.**

The placement of the Metal Connector Plate shall not interfere with other design aspects or the function of the Truss. Any alternate plate must have the same orientation and entirely cover the area footprint of the intended original plate size as shown on the Truss Design Drawing. Examples are shown in Figure 3.6-1.

**3.7 JOINT INSPECTION**

**3.7.1 Critical Joint Inspection.**

The inspection procedures shall apply to joints selected

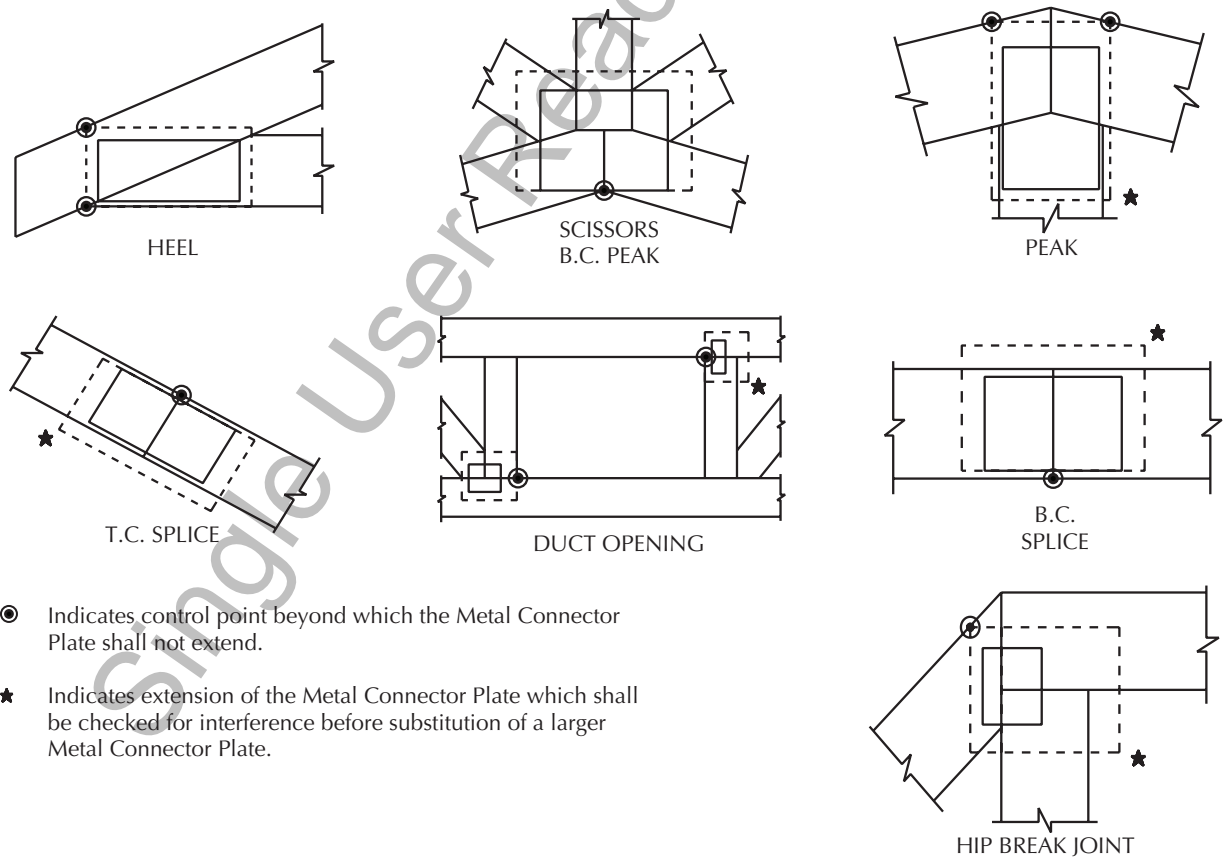

**Figure 3.6-1 Examples of Metal Connector Plate Positionings that Affect the Function of a Truss.**



for inspection. The selection of joints for inspection shall be as defined in the Truss Manufacturer’s In-Plant Quality Assurance Program. No less than one critical joint per Truss selected for inspection, on average across all operational set-up locations at the Truss manufacturing facility, shall be inspected. Critical joints have a joint stress index (JSI), as defined in Section 8.11.3, greater than or equal to 0.80.

**3.7.2 Plate Positioning Procedures.**

**3.7.2.1 Plate Placement.**

A Joint QC Detail (see Figure 3.7-1), illustrating the positioning tolerance, shall be obtained for any joint selected for inspection, except as permitted in Section 3.7.2.2. The actual midpoint of the Metal Connector Plate shall be within the selected fabrication tolerance polygon as calculated by the Truss Designer for each joint per Section 8.11. However, if the Joint QC Detail contains no polygons and the actual midpoint is within 1/8 in. (3 mm) of the specified midpoint, the placement shall be considered acceptable. If all members of a joint selected for inspection are free from characteristics reducing the plate contact area, consisting of lumber characteristics and flattened teeth as outlined in Section 3.7.4, the 0 percent fabrication tolerance polygon shall be used to evaluate plate positioning. If any member contains characteristics reducing the plate contact area, the 0 percent fabrication tolerance polygon shall be permitted to be used provided that Teeth shall be counted and compared to the minimum required Teeth for that member. If fabrication tolerance polygons are smaller than 1/2 in. (13 mm) and the actual midpoint falls outside of both polygons but within 1/2 in.

(13 mm) of the specified midpoint, it shall be permitted to evaluate the plate per Section 3.7.2.2. If the actual midpoint does not meet any of these requirements, the procedures set forth in Section 3.9.1 shall be followed.

**3.7.2.2 Alternative Positioning Procedure.**

For joints designed using standard steel tension values, it shall be permitted that the actual midpoint be within 1/2 in. (13 mm) from the specified midpoint as shown on the Truss Design Drawing and Teeth shall be counted for each member of that joint and compared to the minimum required Teeth. For joints designed using non-standard steel tension values, the provisions of this section shall not apply and the actual midpoint must be positioned as intended, within 1/16 in. (1.6 mm) of the specified midpoint as shown on the Truss Design Drawing.

**3.7.3 Plate Rotation.**

Unless otherwise specified in the Truss Manufacturer’s In-Plant Quality Assurance Program or by the Truss Designer, plate orientation shall not vary by more than 10 degrees from the design position. If the plate rotation does not meet this requirement, the procedures set forth in Section 3.9.1 shall be followed.

**Exception:** If the procedures of Section 3.7.2.2 are followed, a 10 degrees tolerance shall always be allowed.

**3.7.4 Plate Contact Area.**

**3.7.4.1 Lumber Characteristics and Tooth Flattening.**

Any combination of lumber characteristics and tooth

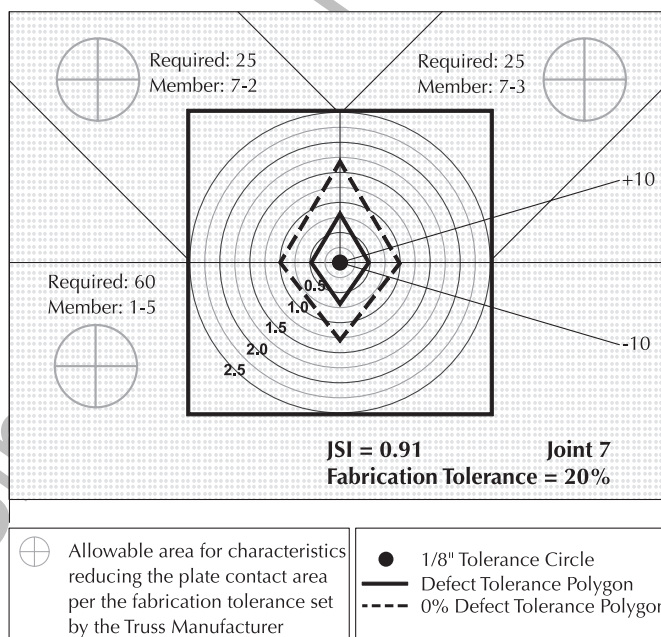

**Figure 3.7-1 Example of a Joint QC Detail and Fabrication Tolerance Polygons.**

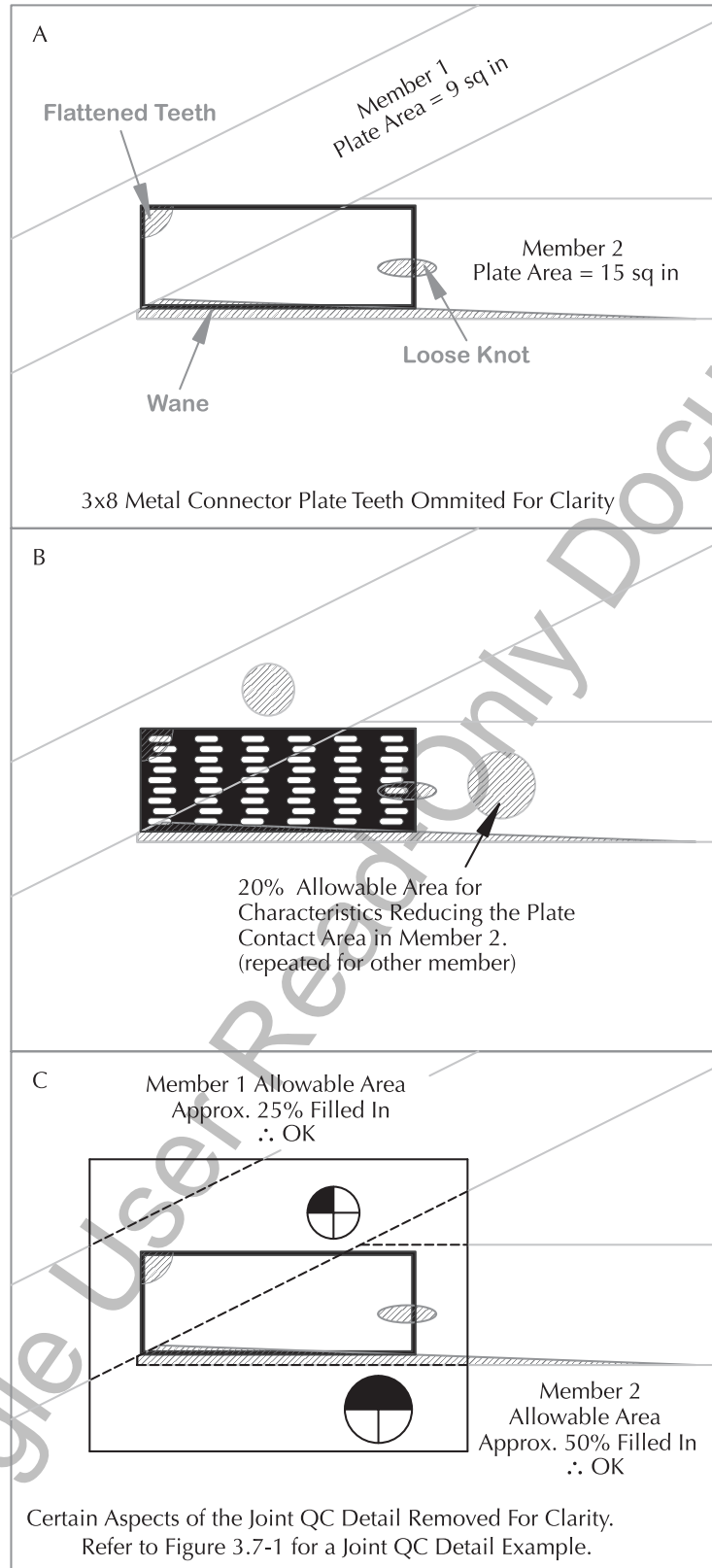

**Figure 3.7-2 Lumber Characteristics and Flattened Teeth in Plate Contact Area.**

**Note:** The maximum allowable area (shown as circles) for the characteristics reducing the plate contact area is equal to the fabrication tolerance set by the Truss Manufacturer and used in the design. In this example, a 20 percent fabrication tolerance was used. Truss Manufacturers have the ability to change this percentage based on their In-Plant Quality Assurance Program.

flattening shall not exceed the fabrication tolerance set by the Truss Manufacturer within the plate contact area except as permitted by Section 3.7.4.2 on any member. The fabrication tolerance shall be permitted to be set at any increment and shall be represented on the Joint QC Detail (see Figure 3.7-1) for the plate contact area of each member. For example, a 0 percent fabrication tolerance assumes that 100 percent of Teeth in the plate contact area are effective. A 20 percent fabrication tolerance assumes that 20 percent of Teeth are in a characteristic reducing the plate contact area (see Figure 3.7-2). Lumber characteristics include, but are not limited to, loose knots, decayed knots, unsound wood, bark, pitch content, holes, and wane. A tooth shall be considered flattened if it meets criteria outlined in Section 3.7.7.2.3.

**3.7.4.2 Fabrication Tolerance Exceeded Tooth Count.**

A member tooth count in accordance with Section 3.7.7 shall be permitted to be done if characteristics reducing the plate contact area are greater than the member’s fabrication tolerance.

**3.7.5 Plate Embedment.**

**3.7.5.1 Plate Embedment Gap Tolerance.**

The maximum allowable embedment gap shall be  $\frac{1}{32}$  in. (1 mm) except as permitted by Section 3.7.5.2. The plate embedment gap shall be measured at the perimeter of the entire plate except the perimeter within a 1 in. (25 mm) distance from lumber ends and edges along joint lines (see Figure 3.7-3).

**3.7.5.2 Excessive Embedment Gap Tooth Count.**

A member tooth count in accordance with Section 3.7.7 shall be permitted to be done when the perimeter of the plate has more than a  $\frac{1}{32}$  in. (1 mm) gap.

**3.7.6 Wood Member-To-Wood Member Gaps.**

**3.7.6.1 Tolerance.**

Except as indicated in Section 3.7.6.2 or as otherwise specified on the Truss Design Drawing, maximum gaps in all joints except floor Truss chord splices shall not exceed  $\frac{1}{8}$  in. (3 mm), where the gap is measured at each edge of the Metal Connector Plate for joints in which the

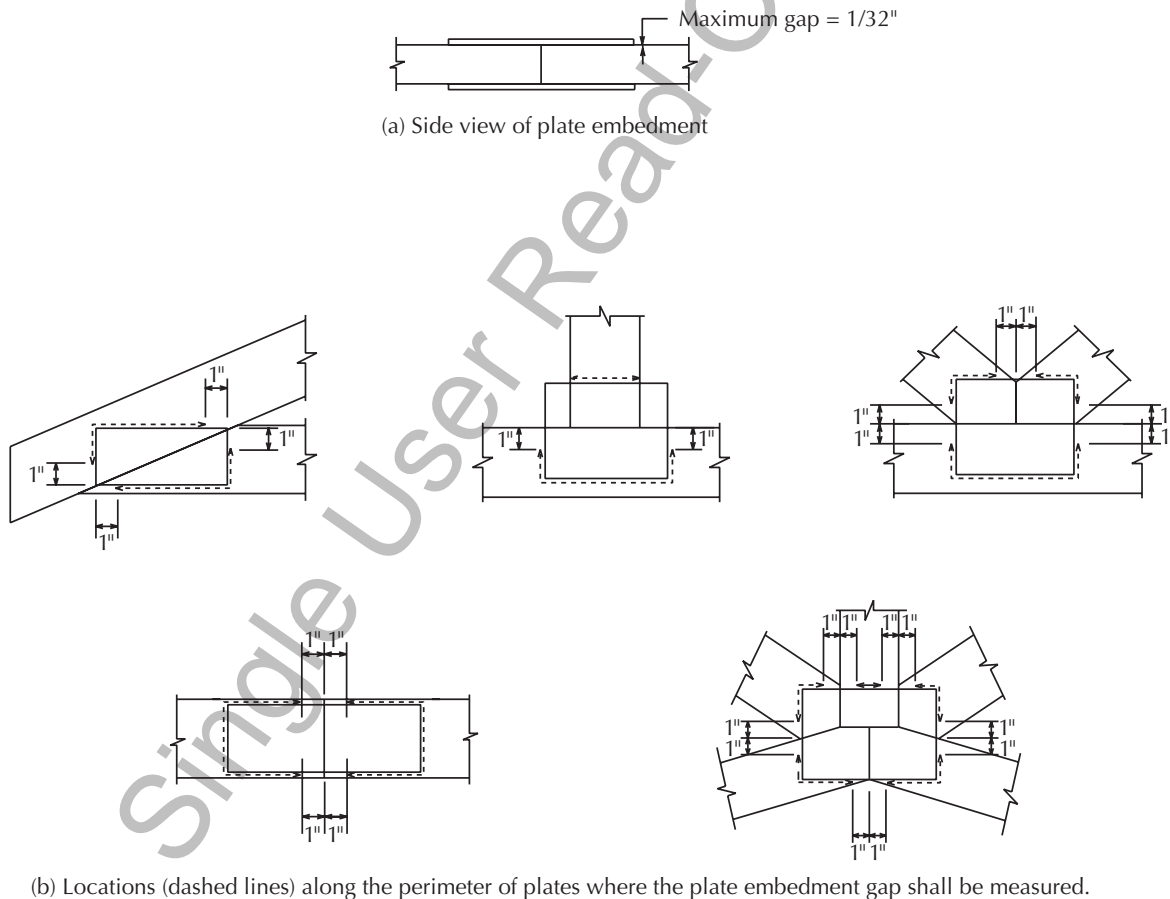

**Figure 3.7-3 Plate Embedment Gap Measurement.**

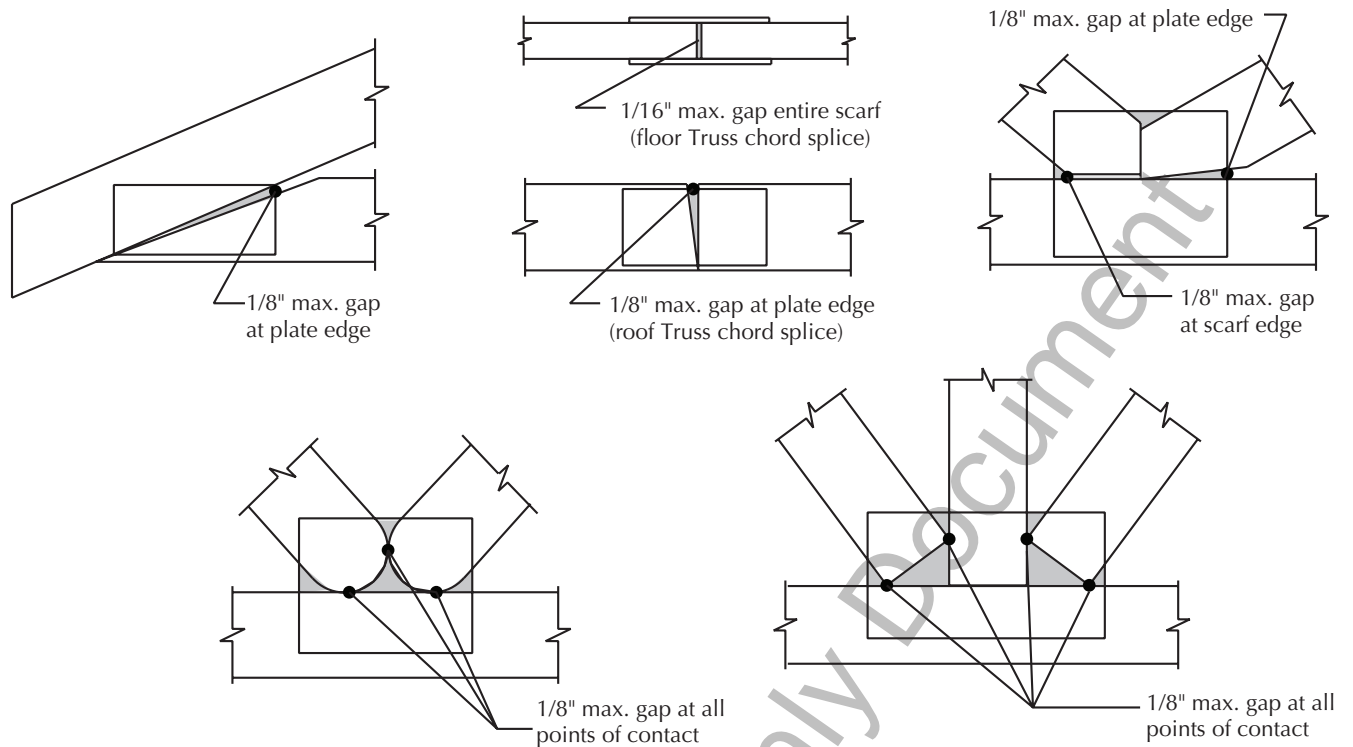

**Figure 3.7-4 Wood Member-to-Wood Member Gaps.**

plate edge is within the scarf, and measured at the end of the scarf for joints in which the plate edge is outside the scarf. Scarf is the portion of the joint in which it is intended that there be wood-to-wood contact between two Wood Members. The maximum gap for floor Truss chord splices shall not exceed  $\frac{1}{16}$  in. (1.5 mm) across the entire scarf. For joints designed with single points of contact between adjacent members as shown on the Truss Design Drawing, the maximum gap between all contact points shall not exceed  $\frac{1}{8}$  in. (3 mm) (see Figure 3.7-4).

**3.7.6.2 Compression Load Tolerance.**

Where a Metal Connector Plate is designed to carry all compression load at the joint without buckling of the plate steel section, the allowable gap shall be that amount of gap used in sizing the Metal Connector Plate as specified on the Truss Design Drawing by the Truss Designer.

**3.7.6.3 Correction Procedure.**

Correction procedures for joints with gaps exceeding these tolerances shall require shimming, unless otherwise specified by a Truss Designer. Shims shall be of galvanized metal, or alternatives approved by a Truss Designer, to obtain firm bearing between members. Metal shims shall be at least  $\frac{3}{4}$  in. (19 mm) wide and long enough to bend over at least 1 in. (25 mm) along the member being shimmed. The metal shim shall be fixed in position with a deformed-shank (i.e., ring- or screw-shank) 6d nail (0.120 in. (3 mm) diameter and 2 in. (5 mm) long), or other fastener capable of resisting withdrawal, to prevent loss or accidental removal (see Figure 3.7-5).

**3.7.7 Effective Tooth Count.**

**3.7.7.1 Total Effective Teeth.**

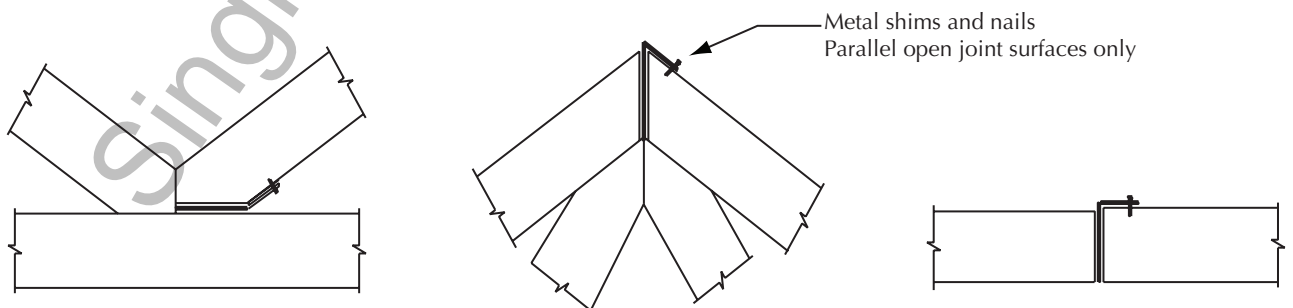

Note: shims are driven to tight contact after Metal Connector Plates are in place.

**Figure 3.7-5 Shimming Gaps.**

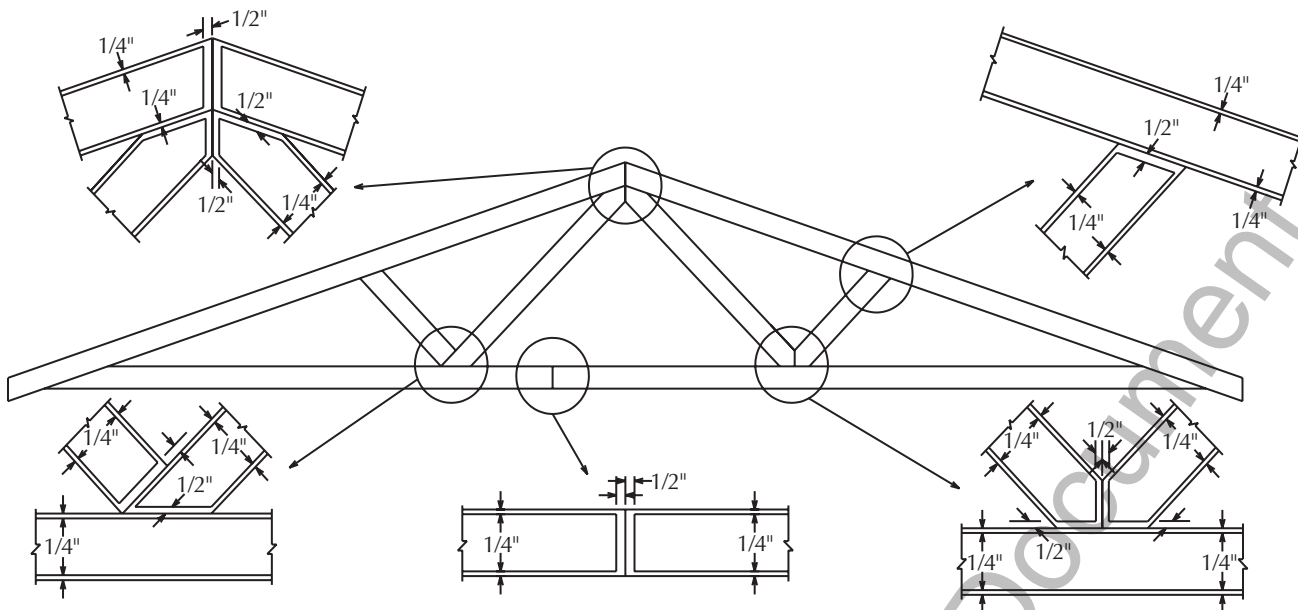

Figure 3.7-6 End and Edge Distances.

The combined number of effective Teeth for both faces of the Truss at each joint in each Metal Connector Plate contact area shall meet or exceed two times the minimum number specified for a single face by the Truss Designer per Section 6.1.2. The number of effective Teeth for a single plated face in a contact area shall be permitted to be up to 15% less than the number specified for a single face per Section 6.1.2, provided the sum of the number of effective Teeth on both faces meets or exceeds the total required number for both faces for that contact area.

**3.7.7.2 Number of Effective Teeth.**

The number of effective Teeth at each plate contact area shall be determined using the requirements in Sections 3.7.7.2.1 through 3.7.7.2.4.

**3.7.7.2.1 Ineffective Teeth – Lumber Characteristics.**

Teeth placed in loose knots, decayed knots, unsound wood, bark, pitch content, holes, wane, and joint gaps shall be considered ineffective. Teeth placed in tight knots shall be considered effective.

**3.7.7.2.2 Ineffective Teeth – End and Edge Distances.**

If the Metal Connector Plate Lateral Resistance design values are based on the Net Area Method, then all Teeth located within the End and Edge Distances according to Figure 3.7-6 shall be considered ineffective.

**3.7.7.2.3 Ineffective Teeth – Tooth Flattening.**

The number of ineffective Teeth due to tooth flattening shall be calculated as twice the number of visibly flattened teeth. A tooth shall be considered flattened if one

quarter ( $1/4$ ) or greater of the tooth length is visible within the tooth-slot opening (see Figure 3.7-7). A tooth shall also be considered flattened if the surface of the wood has raised (i.e., wood lifted up beyond its normal surface plane) within the tooth-slot opening of the Metal Connector Plate.

**3.7.7.2.4 Ineffective Teeth – Embedment Gap.**

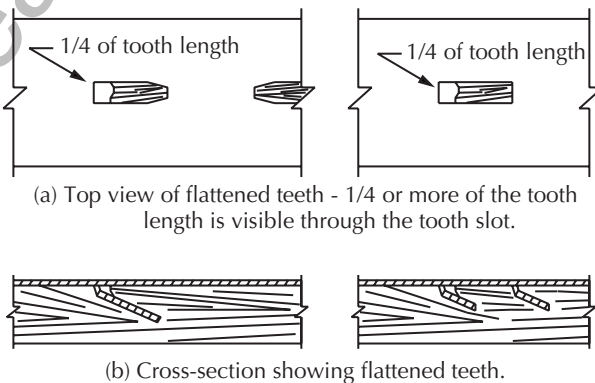

Figure 3.7-7 Tooth Flattening.

Tooth Embedment Gap, G	Tooth Effectiveness
$G = 0''$	119%
$0'' < G \leq 1/32'' (0.03'')$	100%
$1/32'' < G \leq 1/16'' (0.06'')$	60%
$1/16'' < G \leq 3/32'' (0.09'')$	40%
$G > 3/32'' (0.09'')$	0%

Table 3.7-1 Tooth Effectiveness.

The total number of effective Teeth, after excluding Teeth that are considered ineffective per Sections 3.7.7.2.1 through 3.7.7.2.3, shall be determined based on the tooth effectiveness versus tooth embedment gap ratios shown in Table 3.7-1. Tooth embedment gap is defined as the distance between the underside of the embedded Metal Connector Plate and the surface of the Wood Member. Tooth embedment gap shall be measured through the slot opening of the Metal Connector Plate, with an accuracy of 0.01 in. (0.25 mm).

### 3.7.8 Re-evaluation.

Trusses that fail to meet the criteria in Section 3.7 shall be re-evaluated and approved, or repaired as specified by a Truss Designer.

## 3.8 REPRESSING

The repressing of embedded Metal Connector Plates to improve plate embedment shall be permitted.

## 3.9 REPAIR

### 3.9.1 Repair Specifications.

When any installed (i.e., embedded) Metal Connector Plate does not meet the requirements of Sections 3.6 and 3.7, a Truss Designer shall do one of the following:

- (a) Specify the repair removing the plate,
- (b) Specify the repair leaving the plate in place, or
- (c) Review and approve the plate “as is”.

### 3.9.2 Plate Removal.

Metal Connector Plate Teeth installed into lumber which has been damaged (i.e., wood removed, or in violation of Section 3.4.7) by the installation/removal of a previous Metal Connector Plate shall be considered ineffective in the damaged areas.

### 3.9.3 Lumber Condition.

When a Metal Connector Plate is installed in the connection area of lumber that contains tooth holes from a previously installed plate and where the wood is otherwise undamaged, Metal Connector Plate Teeth shall be considered 50% effective. Metal Connector Plate Teeth in areas that do not overlap those of a previously installed plate (i.e., no tooth holes) are not subject to the reduction.

## 3.10 GIRDER TRUSS PLY-TO-PLY CONNECTIONS

Multi-ply girders that are fastened together with nails by the Truss Manufacturer at the manufacturing plant shall

fasten each ply to the next ply per the requirements of the Truss Design Drawing. The manufacturing plant shall be permitted to place the second ply onto the first ply and nail the two plies together and then place the third ply onto the two ply Truss and nail the third ply into the two ply Truss below it, etc, without turning the multi-ply Truss over. The In-Plant Quality Control Assurance Program (see Section 3.2) shall monitor the ply-to-ply nailing process.

Single User Read-Only Document

## CHAPTER 4

# METAL CONNECTOR PLATE MANUFACTURING

### 4.1 GENERAL

#### 4.1.1 Scope.

Metal Connector Plates used in the manufacturing of wood Trusses shall be manufactured to the requirements of Chapter 4 and to other applicable sections of this Standard. This chapter is designed to provide the Metal Connector Plate manufacturer with procedures and production tolerances for Metal Connector Plates that are used in wood Truss manufacturing.

#### 4.1.2 Requirements.

The provisions of Chapter 4 of this Standard shall be included in the Quality Assurance Program (QAP) of each Metal Connector Plate manufacturer.

### 4.2 QUALITY ASSURANCE PROGRAM (QAP)

#### 4.2.1 Documentation.

The Metal Connector Plate manufacturer shall have a written QAP approved by executive management.

#### 4.2.2 QAP Manager.

Executive management shall designate a QAP manager who shall report directly to executive management.

##### 4.2.2.1 Selection.

The QAP manager shall not be in the Metal Connector Plate production department.

##### 4.2.2.2 Delegation.

The QAP manager shall be permitted to delegate QAP functions to others, provided all specified data, reports, and noncompliance to this section are submitted to the manager.

##### 4.2.2.3 Authority.

The QAP manager shall have the authority to, and shall, reject any Metal Connector Plates that do not meet the specifications of Chapter 4. Metal Connector Plates so rejected shall be disposed of in such a way that they will not be used in the manufacturing of wood Trusses.

##### 4.2.2.4 Responsibility.

The QAP manager shall inform each Person directly responsible for the procurement of materials and the production of Metal Connector Plates of the requirements of Chapter 4 of this Standard that are applicable to that

Person's function. Each Person shall be responsible for monitoring of the particular Specifications that are assigned to that Person's job function.

##### 4.2.2.5 Record Retention.

The QAP manager shall maintain records and reports for a minimum period of three years.

### 4.3 PRODUCTION STEEL

#### 4.3.1 Specifications.

All steel used in the manufacturing of Metal Connector Plates shall meet specifications of the Metal Connector Plate manufacturer including minimum yield strength, minimum ultimate tensile strength, minimum thickness, and any other parameters required to assure adequate plate performance.

#### 4.3.2 Master Coil.

##### 4.3.2.1 Certification.

Each master coil of steel shall be marked and shall have a certified report from the producing steel mill that includes the grade of steel, the mechanical properties of the steel, and the chemical properties of the steel.

##### 4.3.2.2 Identification.

Each production coil of steel processed from the master coil shall be marked to indicate the master coil from which it was slit.

#### 4.3.3 Steel Sheet.

##### 4.3.3.1 Requirements.

Metal Connector Plates shall be of galvanized steel conforming to the requirements of Section 4.3.3.2 or Section 4.3.3.3, aluminum-zinc alloy coated steel conforming to the requirements of Section 4.3.3.4, or stainless steel conforming to the requirements of Section 4.3.3.5.

##### 4.3.3.2 Hot-Dip Galvanized Steel.

Hot-dip galvanized steel shall meet or exceed yield and ultimate tensile strengths of *ASTM A653/A653M*, Structural Grade 33, and galvanized coating shall meet or exceed coating designation G60.

##### 4.3.3.3 Electrolytic Galvanized Steel.

Electrolytic galvanized steel shall meet or exceed *ASTM A879* coating designation 30Z30Z. Structural properties shall meet or exceed those specified in Section 4.3.3.2.



#### 4.3.3.4 Aluminum-Zinc Alloy Coated Steel.

Aluminum-zinc alloy coated steel shall meet or exceed *ASTM A792/A792M*, *AZ50* coating weight. Structural properties shall meet or exceed those specified in Section 4.3.3.2.

#### 4.3.3.5 Stainless Steel.

Stainless steel shall meet or exceed *ASTM A167* or *A240/A240M*. Structural properties shall meet or exceed those specified in Section 4.3.3.2.

#### 4.3.4 Steel Thickness.

Minimum thickness in inches (or mm for metric units), including both uncoated and coated thicknesses, if galvanized or aluminum-zinc alloy coated, shall be specified for each type of Metal Connector Plate.

#### 4.3.5 Records.

The Metal Connector Plate manufacturer shall maintain records that include the following information for each master coil of steel used in Metal Connector Plate production:

- (a) Name of steel producer;
- (b) Material description and specification;
- (c) Heat number;
- (d) Yield point;
- (e) Tensile strength;
- (f) Elongation; and
- (g) Chemical analysis.

#### 4.3.6 Nail-on Plates.

Metal Connector Plates without integral Teeth (nail-on plates), shall provide some means, such as holes, dimples, bosses, or marked pattern, to indicate the location of any separately applied nails for fasteners.

#### 4.3.7 Tooth Tolerances.

Metal Connector Plates shall be manufactured with all holes, plugs, Teeth, or prongs properly spaced and properly formed per the requirements of the Metal Connector Plate manufacturer.

#### 4.3.8 Marking.

All Metal Connector Plates 3 in. (76 mm) in width or wider, and 25 percent of Metal Connector Plates less than

3 in. (76 mm) in width, shall be individually marked with the name or symbol of the manufacturer.

#### 4.3.9 Regalvanizing.

Regalvanizing the Metal Connector Plates in accordance with *ASTM A153* after the stamping operation shall not be necessary unless specified by the Truss Designer or the Building Designer.

### 4.4 PRODUCTION

#### 4.4.1 Measurement.

Prior to and during production, each production coil of steel shall be measured to the closest 0.001 in. (0.02 mm) for conformance to minimum thickness specification. Steel with a thickness measurement less than specification shall not be used.

#### 4.4.2 Visual Observations.

During the stamping of Metal Connector Plates, the machine operator shall visually observe production Metal Connector Plates to assure proper forming as follows:

- (a) Metal Connector Plate primary surface shall be flat or as specified;
- (b) Metal Connector Plate Teeth shall be uniform, with no Teeth malformed;
- (c) Roots of Teeth where they join the flat plane of the Metal Connector Plate shall show no abnormal fracture; and
- (d) Teeth shall be formed as specified and shall have the appropriate angle to the plane of the Metal Connector Plate.

### 4.5 IDENTIFICATION

#### 4.5.1 Plate Markings.

Metal Connector Plates shall be marked as specified in Section 4.3.8.

#### 4.5.2 Package Markings.

Each package or individual shipping unit shall be marked to indicate the production run and master coil of steel in order to provide recall ability should quality problems be identified at a later date.

### 4.6 INSPECTION

#### 4.6.1 Frequency.

The QAP manager shall obtain a sample from each pro-

duction line at a minimum of five times per week, on a random, unannounced schedule. Time, date, production line, and master coil identification code shall be recorded for each sample.

#### 4.6.2 Requirements.

The QAP manager shall inspect each Metal Connector Plate with all data recorded in a journal for the following characteristics:

- (a) Time and date of production, production line, master coil identification code and series, gauge, and size of Metal Connector Plate shall be recorded.
- (b) Metal Connector Plates shall be visually inspected for misforming, flatness, and steel fracture. All Teeth and cut outs shall be uniformly consistent.
- (c) Steel thickness shall be measured to the closest 0.001 in. (0.02 mm).
- (d) Steel hardness shall be measured on the Rockwell B scale to the closest +/- 3. Optionally, the hardness of the production coil shall be measured at time of sampling.
- (e) Width and length of the Metal Connector Plate shall be measured to the closest  $\frac{1}{64}$  in. (0.5 mm).
- (f) Several Teeth in each Metal Connector Plate shall be bent at the root line to determine number of bends to fracture. Grip and bend procedure is to be defined in the QAP.

#### 4.7 TOLERANCES

Inspected Metal Connector Plates shall be in accordance with the following:

- (a) Visual observations shall be a qualitative decision by the QAP manager as to acceptability;
- (b) Steel thickness shall be equal to or greater than the minimum specification;
- (c) Steel hardness shall be in a range specified by the QAP manager;
- (d) Metal Connector Plate Width shall not be more than  $\frac{1}{32}$  in. (1.0 mm) undersized;

(e) Metal Connector Plate Length shall not be more than  $\frac{1}{64}$  in. (0.5 mm) less than the total length for each 1 in. (25 mm) of specified length; and

(f) Metal Connector Plate root bend test requirements shall be determined by the QAP manager.

#### 4.8 ACCEPTANCE

Metal Connector Plates meeting the specifications of Chapter 4 of this Standard are acceptable for use in the manufacturing of metal-plate-connected wood Trusses.

#### 4.9 REJECTION

##### 4.9.1 Nonconforming Metal Connector Plates.

If the press operator or supervisor visually observes nonconforming Metal Connector Plates, operation of that production line shall cease until corrections are made, and the QAP manager shall be notified.

##### 4.9.2 Sampling Previous Production.

The QAP manager shall sample previous production and shall reject Metal Connector Plates that do not meet these specifications.

Single User Read-Only Document

## CHAPTER 5

# PERFORMANCE EVALUATION OF METAL CONNECTOR PLATED CONNECTIONS

### 5.1 GENERAL

#### 5.1.1 Scope.

Chapter 5 of this Standard includes three test procedures to determine the performance of metal connector plated connections:

- (a) Determination of lateral resistance of Metal Connector Plate Teeth (see Section 5.2).
- (b) Determination of shear strength of Metal Connector Plates (see Section 5.3).
- (c) Determination of Tensile Strength of Metal Connector Plates (see Section 5.4).

The results of these tests shall be used in designing metal connector plated connections.

#### 5.1.2 Testing Apparatus Requirements.

##### 5.1.2.1 General.

The testing apparatus used for each of the Standard methods of test specified in Chapter 5 of this Standard shall be in accordance with this section.

##### 5.1.2.2 Testing Machine.

A testing machine shall be used which is capable of applying tensile and compressive loads at a constant rate of crosshead movement, and which is calibrated in accordance with *ASTM E4*.

##### 5.1.2.3 Hydraulically Driven Testing Machine.

Hydraulically driven testing machines shall be controlled by a valve allowing a constant rate of flow of hydraulic fluid. Hydraulically driven testing machines controlled by a pressure valve shall not be acceptable.

##### 5.1.2.4 Gripping Devices.

Gripping devices shall be used which are capable of carrying the test joints to failure and allowing for uniform axial loading of the Test Specimen without introducing bending in the joint.

##### 5.1.2.5 Measuring Devices.

Measuring devices with an accuracy of 0.001 in. (0.02 mm) shall be used to measure the separation of, or slip

between, the Wood Members at the joint being tested, or the slip between the Metal Connector Plate and Wood Member.

### 5.2 STANDARD METHOD OF TEST FOR DETERMINING LATERAL RESISTANCE OF METAL CONNECTOR PLATE TEETH

#### 5.2.1 Calculation Permitted For Nail-on Plates.

Lateral resistance design values for nail-on plates, meaning Metal Connector Plates without integral Teeth that are connected to the wood using only separately applied nails or other fasteners, shall be permitted to be established solely using recognized design criteria for the separately applied nails or other fasteners such as those criteria given in the *ANSI/AWC NDS*.

#### 5.2.2 Metal Connector Plates.

##### 5.2.2.1 Test Specimen Selection.

Metal Connector Plates selected for Test Specimen fabrication shall be typical of production. Test coil metal shall be sampled from the production inventories of the Metal Connector Plate manufacturers that are procured with a specified minimum yield or grade. Where such samples are found to exceed the specified minimum yield by more than 7 ksi (48.26 MPa), the lateral resistance shall be multiplied by the adjustment factor ( $R_y$ ) shown in Equation E5.2-1. Where the thickness of the test coil steel exceeds the minimum specified thickness by more than 5 percent, the lateral resistance shall be multiplied by the adjustment factor ( $R_t$ ) shown in Equation E5.2-2. If both yield and thickness exceed the above specified limits, both adjustment factors  $R_y$  and  $R_t$  shall be applied to the lateral resistance simultaneously.

$$R_y = (F_{y,spec} / F_{y,test})^{(1.2 \times G_{test} - 0.4)} \leq 1.0 \quad (\text{E5.2-1})$$

where:

$R_y$  = Adjustment factor to account for steel yield

$F_{y,spec}$  = Specified minimum steel yield strength

$F_{y,test}$  = Average measured steel yield strength of test plates

$G_{test}$  = Average measured specific gravity (oven-dry basis) of wood used in test joints

$$R_T = (t_{\text{spec}}/t_{\text{test}})^{(0.7)} \leq 1.0 \quad (\text{E5.2-2})$$

where:

$R_T$  = Adjustment factor to account for steel thickness

$t_{\text{spec}}$  = Specified minimum steel thickness

$t_{\text{test}}$  = Average measured steel thickness of test plates

### 5.2.2.2 Cleaning Plates.

The Metal Connector Plates shall be washed in a solvent so that they are free of oil and any substance which will alter the Metal Connector Plate performance.

### 5.2.2.3 Test Specimen Design.

The Test Specimens shall be designed to produce the type of failure intended for each test. The plate dimension parallel to the loading direction,  $l'$ , shall be the maximum which consistently produces withdrawal failure of the Teeth without inducing net section steel failure. The plate dimension perpendicular to the loading direction shall comply with Section 5.2.6.

### 5.2.2.4 Number of Samples.

The number of plates selected shall be sufficient to fabricate five joints for each combination of plate type, plate/wood orientation, wood face width, Species Combination, and fabrication method tested.

## 5.2.3 Solid Metal Control Specimens.

### 5.2.3.1 Number of Samples.

A Solid Metal Control Sample shall be taken at each end of the section of each slit coil used to manufacture the Metal Connector Plates used in Section 5.2.2. A minimum of three solid metal control specimens shall be machined from each Solid Metal Control Sample.

### 5.2.3.2 Control Specimen.

The solid metal control specimens shall be machined into standard rectangular Test Specimens with a reduced cross-section (see Figure 5.2-1).

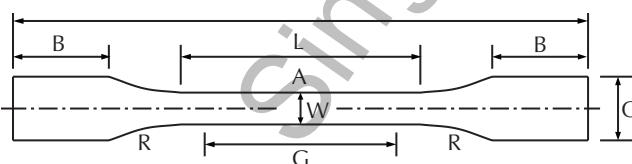

For dimensions, see *ASTM E8*.

**Figure 5.2-1 Solid Metal Control Specimen.**

## 5.2.4 Wood Members.

### 5.2.4.1 General.

The Sample Block for determining oven-dry specific gravity shall be taken within 12 in. (305 mm) of where the Metal Connector Plates will be embedded. Each Sample Block shall be stored in an individual impermeable package to prevent any change in moisture content before weighing. The Wood Member shall be used for assembly at moisture content of 11 percent or greater for solid-sawn lumber, and 7 percent or greater for Structural Composite Lumber. The Sample Block for determining moisture content shall be taken at the time of Test Specimen fabrication, within 12 in. (305 mm) from where the Metal Connector Plates will be embedded.

### 5.2.4.2 Test Specimen Characteristics.

The specific gravity, moisture content, and moisture content adjustments of the Wood Members shall be determined by *ASTM D2395* for specific gravity, and *ASTM D4442* or *ASTM D7438* for moisture content testing, except that the parallel to load member in joints at the AE and EE orientations shall not be required to have these properties determined.

### 5.2.4.3 Clear Wood Under Plates.

Wood Members shall have clear wood in the area in which the Metal Connector Plates will be embedded.

### 5.2.4.4 Test Specimen Length.

The length of the Wood Members shall be determined according to the type of gripping apparatus used. In no case shall the gripping apparatus interfere with the connection at the joint or the measuring device. The width of the Wood Members shall comply with Section 5.2.6.2.

### 5.2.4.5 Number of Samples.

The number of Wood Members selected shall be sufficient to fabricate five joints for each combination of plate type, plate/wood orientation, wood face width, Species Combination, and fabrication method tested.

## 5.2.5 Embedment Methods.

### 5.2.5.1 Design Values.

Design values intended for Metal Connector Plates pressed hydraulically shall be obtained by testing hydraulically embedded Test Specimens as shown in Figure 5.2-2. Design values intended for Metal Connector Plates pressed with a single pass roller shall be obtained by testing a Metal Connector Plates Test Specimen embedded with a single pass roller press as shown in Figure A5.2-3. Design values determined for a specific roller diameter shall be applicable to Metal Connector Plates

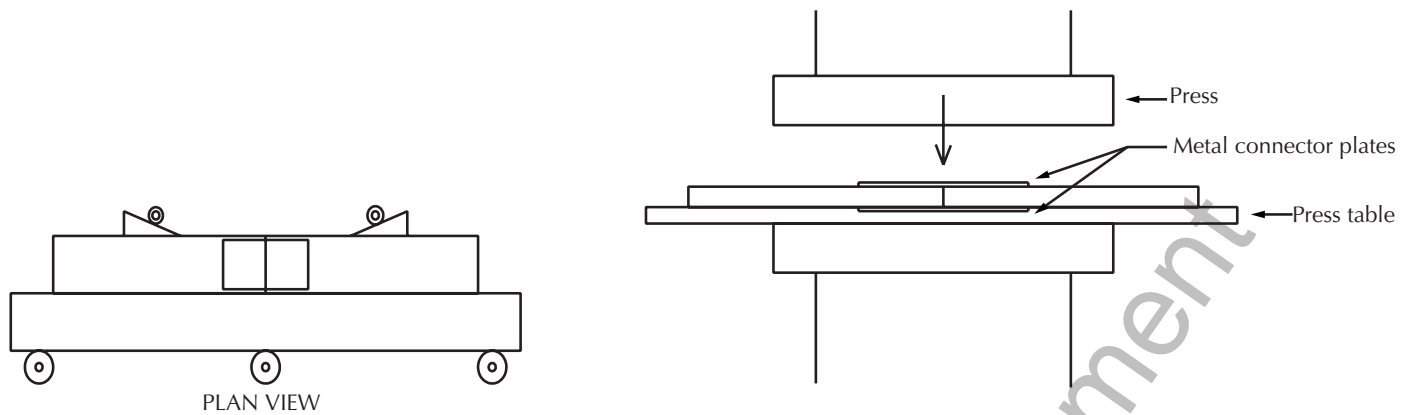

STEP 1. Jig pieces on Press table and position Metal Connector Plate. Clamps and straight edge assure wood members in joint are colinear.

STEP 2. Press Metal Connector Plate.

**Figure 5.2-2 Suggested Joint Fabrication Setup.**

pressed with the same diameter roller or greater. Design values determined for single pass roller presses are not prohibited from being used for double pass roller presses and hydraulic pressing equipment.

#### 5.2.5.2 Reduction Value.

In lieu of testing Metal Connector Plates for use with a single pass, full embedment roller press as specified in Section 5.2.5.1, a reduction value,  $Q_R$ , determined in accordance with Annex A5.2, shall be permitted. This reduction does not apply to plates embedded using full embedment hydraulic platen presses, multiple roller systems which utilize partial embedment followed by full embedment rollers, and combinations of partial embedment roller/hydraulic presses that feed Trusses into a stationary finish roller.

### 5.2.6 Test Specimen Fabrication.

#### 5.2.6.1 Plate Thickness.

The Metal Connector Plate thickness shall be measured to the nearest 0.001 in. (0.02 mm) before the Test Specimen is assembled.

#### 5.2.6.2 Assembly.

The Test Specimens shall be assembled as shown in Figure 5.2-3 for the Gross Area Method and Figure 5.2-4 for the Net Area Method.

##### 5.2.6.2.1 Gross Area Method.

End and Edge Distances shall be zero for the Gross Area Method. For AA and EA orientations, the actual width of the Wood Members shall be reduced to the Metal Connector Plate dimension perpendicular to the grain before embedment.

##### 5.2.6.2.2 Net Area Method.

For AA and EA orientations, the Metal Connector Plate dimension perpendicular to the grain shall be no more than  $\frac{1}{2}$  in. (12.7 mm) less than the Wood Member width.

Metal Connector Plate Teeth at the wood edges and at the member interface within the applicable End or Edge Distance shall be ground off as shown in Figure 5.2-4. Edge Distance shall be  $\frac{1}{4}$  in. (6 mm) measured perpendicular to wood grain. End Distance shall be  $\frac{1}{2}$  in. (13 mm) measured parallel to wood grain and applies to joints loaded parallel to grain (AA and EA orientations). Alternatives to these  $\frac{1}{4}$  in. (6mm) and  $\frac{1}{2}$  in. (13 mm) standard values shall be permitted provided the alternative values are used in the design process.

#### 5.2.6.3 Full Contact of Wood Members.

The Test Specimens shall be assembled such that the two Wood Members are held tightly together, in full contact against each other, before the Metal Connector Plates are attached and during the embedment of the plates.

#### 5.2.6.4 Joint Fabrication Setup.

The Metal Connector Plates shall be embedded on both sides of the Test Specimens in the same manner as typically used in the manufacture of Trusses. Any presetting techniques used in embedding the plates, such as tapping plates in place prior to roller pressing, shall be typical of those used in the manufacture of Trusses and fully described in the test report. A suggested joint fabrication setup is shown in Figure 5.2-2 for hydraulically pressed manufacturing methods.

Keeper Nails, or any supplemental fasteners that are not an integral part of the joint design method, shall not be used in the Metal Connector Plates lateral resistance

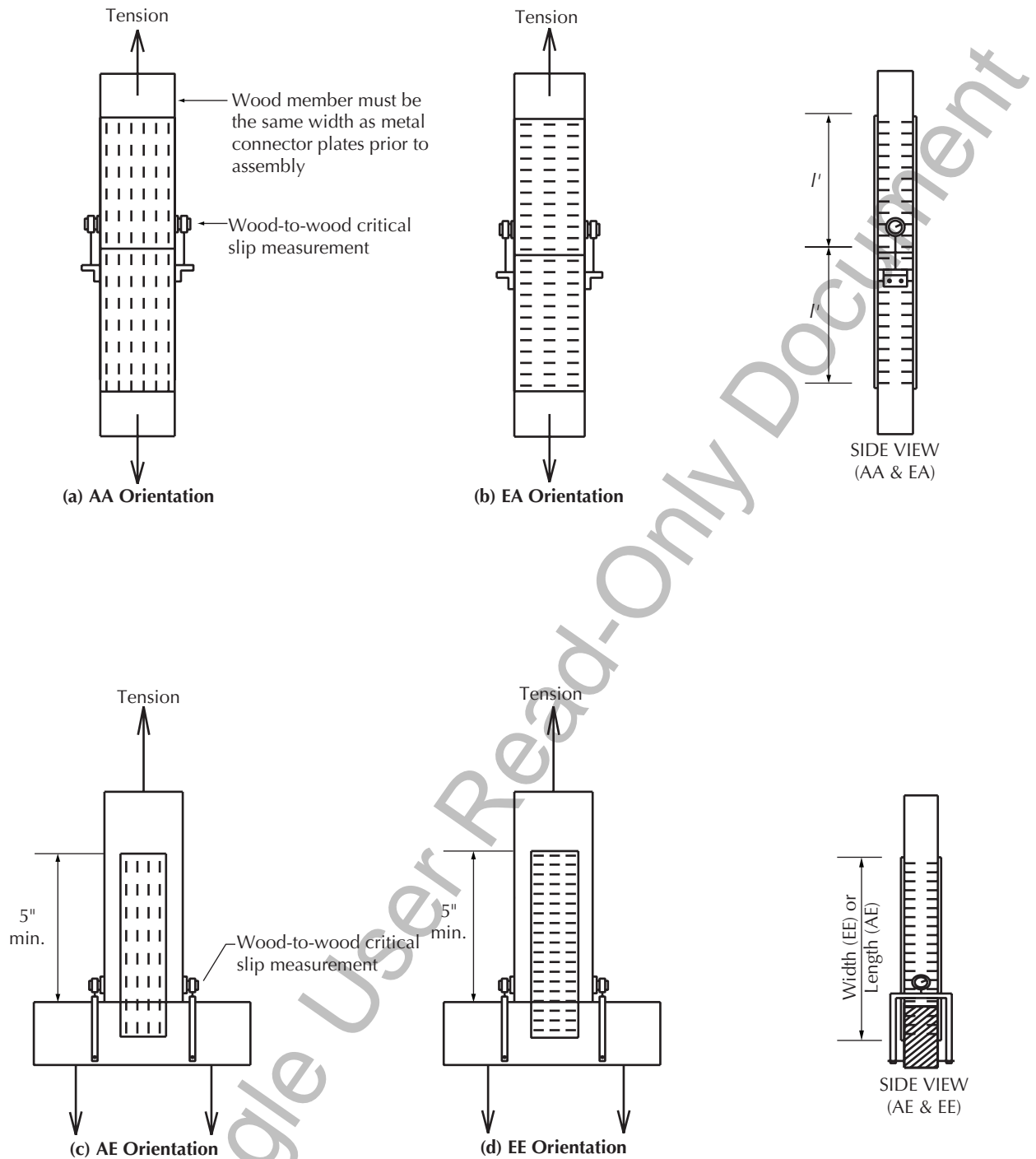

Figure 5.2-3 Test Specimen Fabrication for Gross Area Method.

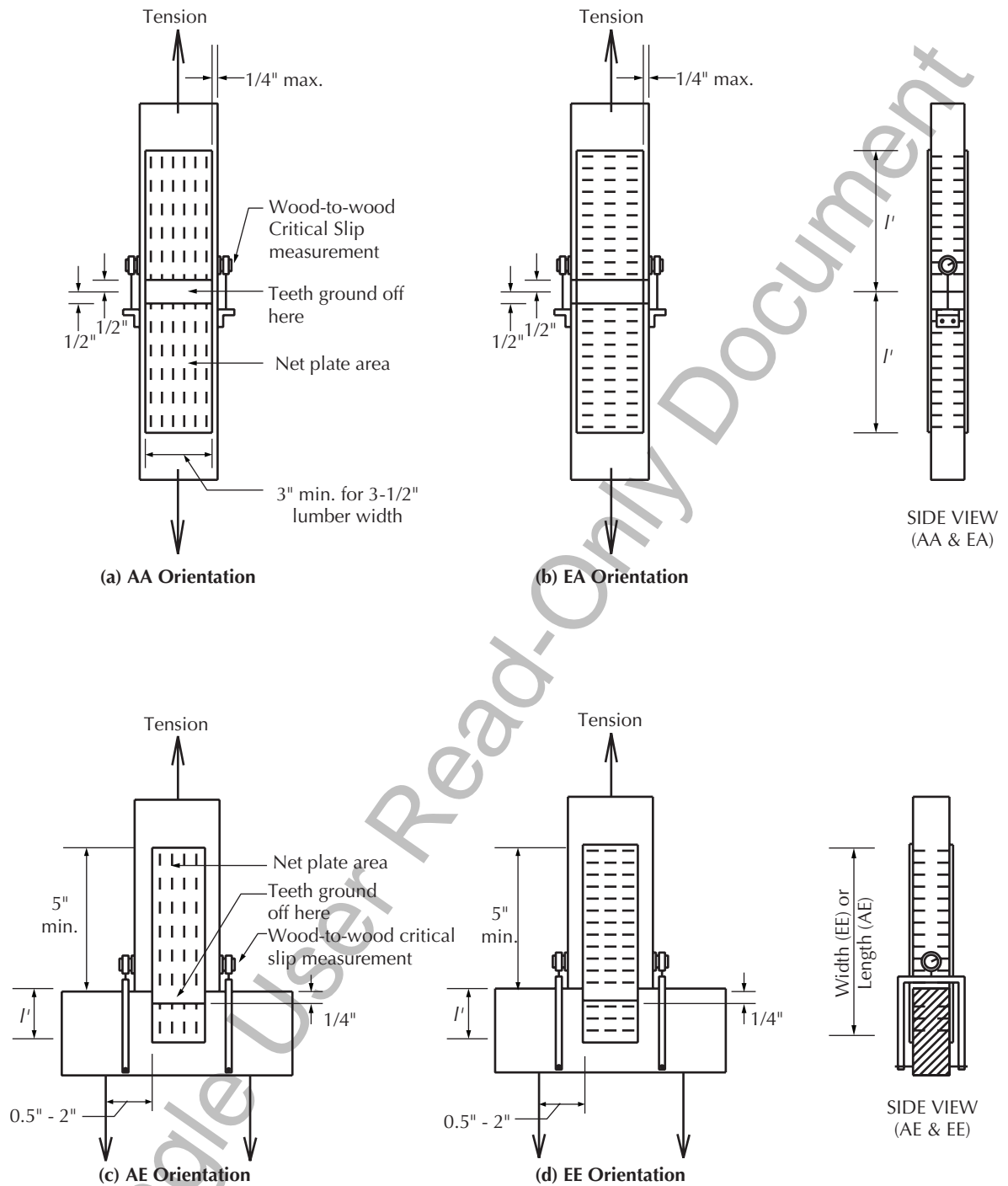

Figure 5.2-4 Test Specimen Fabrication for Net Area Method.



evaluation testing. Where Keeper Nails are an integral part of the joint design method, are used in the manufacturing process, and are intended to be used in production Trusses, they shall be installed in the plate area in the same proportions and with the same distribution as those intended to be used in production.

#### 5.2.6.5 Plate Embedment.

Metal Connector Plates shall be embedded in clear wood, and shall be installed so that the Teeth are fully embedded in the Wood Member and no gaps remain between the Metal Connector Plate and the Wood Member. Over-pressing shall be avoided, so that the Metal Connector Plates do not embed into the Wood Member more than half the steel thickness.

#### 5.2.6.6 Wood-to-Plate Slip.

Test Specimens assembled for evaluating Metal Connector Plates perpendicular to the grain of the Wood Member shall be fabricated by extending the Metal Connector Plate a minimum of 5 in. on the vertical Wood Member. To obtain the wood-to-plate slip, either measure movement wood-to-wood, or measure movement wood-to-plate as shown in Figure 5.2-5. When slip is measured wood-to-wood, the plate is permitted to be glued to the vertical Wood Member to minimize plate slip on this member.

#### 5.2.6.7 Structural Composite Lumber.

When Metal Connector Plates are tested with Structural Composite Lumber (SCL), the test plates shall be embedded into the same surface of the SCL as anticipated in service. If plates will be applied in service to both the pressed face and the non-pressed face of the SCL, separate series of tests shall be required for plates on each of these surfaces.

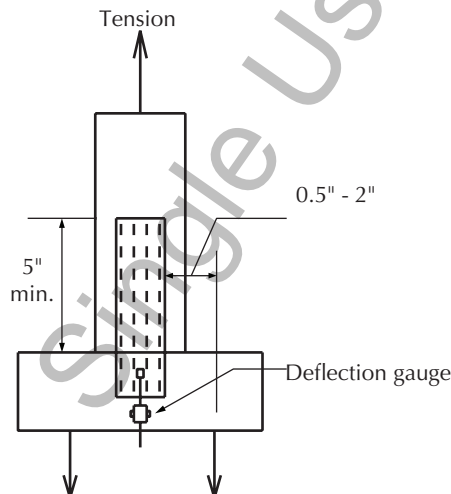

Figure 5.2-5 Fabrication of Test Specimen for Measuring Wood-To-Plate Slip.

### 5.2.7 Test Specimens Required.

#### 5.2.7.1 Wide Face Lateral Resistance Values.

##### 5.2.7.1.1 Replicates and Orientations.

For each Species Combination and embedment method selected for testing, a minimum of five Test Specimens shall be tested for each of the following connector plate/wood orientations:

- Load parallel to grain, Metal Connector Plate Length parallel to load (AA orientation, Figures 5.2-3(a) and 5.2-4(a)).
- Load parallel to grain, Metal Connector Plate Length perpendicular to load [EA orientation, see Figures 5.2-3(b) and 5.2-4(b)].
- Load perpendicular to grain, Metal Connector Plate Length parallel to load [AE orientation, see Figures 5.2-3(c) and 5.2-4(c)].
- Load perpendicular to grain, Metal Connector Plate Length perpendicular to load [EE orientation, see Figures 5.2-3(d) and 5.2-4(d)].

##### 5.2.7.1.2 Symmetrical Plate Teeth.

When Metal Connector Plate Teeth, or groups of Teeth, are symmetrical across both the slot (or plug) length and slot (or plug) width, the EA and EE orientations need not be tested and shall be taken as equal to the AA and AE orientations, respectively.

#### 5.2.7.2 Narrow Face Lateral Resistance Values.

##### 5.2.7.2.1 Gross Area Tests.

Narrow Face lateral resistance design values for Metal Connector Plates shall be obtained for plates tested by the Gross Area Method by testing a minimum of five Test

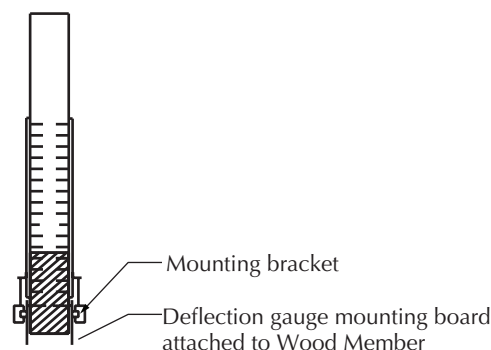

Specimens for a Species Combination for each orientation specified in Section 5.2.7.1.

#### 5.2.7.2.2 Alternative.

In lieu of testing per Section 5.2.7.2.1, Narrow Face lateral resistance design values for Metal Connector Plates using the Gross Area Method shall be determined by reducing design values determined for Metal Connector Plates pressed in the wide face of the Wood Member, as determined in Section 5.2.7.1, by 15 percent.

### 5.2.8 Test Procedure to Determine Lateral Strength Capacities.

#### 5.2.8.1 Measurements.

After assembly, measure the Metal Connector Plate Length and Width to the nearest 0.03 in. (0.10 mm). Count the number of Teeth on each side of the joint.

#### 5.2.8.2 Time Period.

A minimum period of seven days shall elapse between assembly and testing of the Test Specimens.

#### 5.2.8.3 Loading Procedure.

Conduct tests on the Metal Connector Plate Test Specimens at a constant movable crosshead speed to attain ultimate load in not less than one minute. Record the rate of loading used. Take readings of both the applied load and the amount of corresponding slip indicated by each measuring device at intervals not exceeding 400 lbs. (1780 N) to permit plotting of an accurate load-deformation curve. Obtain at least three readings before Critical Slip (see Chapter 1) is reached. Continue the test until the ultimate failure load is reached. Load at Critical Slip shall be determined by linear interpolation between points in the load-deformation curve.

#### 5.2.8.4 Testing Procedure for Solid Metal Control Specimens.

Conduct tests on the solid metal Control Specimens in accordance with *ASTM E8* procedures. Thickness shall be measured to the nearest 0.0001 in. (0.003 mm) and width to the nearest 0.001 in. (0.02 mm). Thickness of galvanized (or other) coating, if present, shall be measured or the coating shall be removed prior to thickness measurement. In lieu of coating measurement, the thicknesses given in Section 6.3.4.1.3 shall be permitted to be used for coating thickness.

### 5.2.9 Calculations.

#### 5.2.9.1 General.

The calculations specified herein shall establish the basic allowable lateral resistance design values, for the

four specified orientations, on a load per unit area basis:  $V_{LRAA}$ ,  $V_{LRAE}$ ,  $V_{LREA}$ , and  $V_{LREE}$  [psi/pair (N/mm<sup>2</sup>/pair)].

#### 5.2.9.2 Lateral Resistance Design Values.

Design values for lateral resistance,  $V_{LR}$ , shall be the lesser of the following values, which shall be further adjusted in accordance with Section 5.2.2.1 when applicable, and expressed on a unit plate area basis:

- (a) At Critical Slip, divide the load by 1.3 for each Test Specimen. Average the test values for each Metal Connector Plate orientation for all Test Specimens and multiply the resulting average value by  $R_G$ , given in Section 5.2.9.3, and  $R_Y$  and  $R_T$  given in Section 5.2.2.1.
- (b) At ultimate failure, divide the load by 3.2 for each Test Specimen. Average the test values for each Metal Connector Plate orientation for all Test Specimens and multiply the resulting average value by  $R_G$ , given in Section 5.2.9.3, and  $R_Y$  and  $R_T$  given in Section 5.2.2.1.

#### 5.2.9.3 Adjustment Factor for Specific Gravity of Test Specimens Exceeding Specified Value ( $R_G$ ).

The value of  $R_G$  shall be the lesser of  $G_{\text{specified}}/G_{\text{test}}$  or 1.0; where  $G_{\text{specified}}$  is the published average specific gravity of the Species Combination listed in an approved design standard or *ASTM D2555*, and  $G_{\text{test}}$  is the average specific gravity of the wood in the five or more Test Specimens producing the loads used in the calculations shown in Section 5.2.9. Both  $G_{\text{specified}}$  and  $G_{\text{test}}$  shall be based on volume at oven-dry moisture content.  $G_{\text{specified}}$  shall be for the species to which the design values will apply. This species is permitted to be different from the species tested.

#### 5.2.10 Report.

The report shall include the following information:

- (a) Date of fabrication, date of test, and date of report.
- (b) Test sponsor and test agency.
- (c) Complete description of test method and loading procedure used if there are any deviations from the prescriptive methods in this Standard.
- (d) Description of pressing equipment including roller diameter, roller press description, jiggging apparatus, and any plate setting or pre-pressing techniques, if used.

- (e) The number of Teeth in the failure zone.
- (f) Rate of testing (crosshead speed or initial rate of load application).
- (g) Elapsed time of test.
- (h) Load deformation curve, or a minimum of three load, and corresponding deformation, readings prior to achieving Critical Slip.
- (i) Load at Critical Slip.
- (j) Maximum load obtained before failure and maximum load per plate unit values.
- (k) Description of type and path of failure.
- (l) Wood Member sizes and species.
- (m) Either a detailed drawing of the Metal Connector Plate showing type, model, size, thickness, material and manufacturer, or a written description of the plate noting size, thickness, tooth spacing, material and manufacturer along with a photograph showing both faces.
- (n) Moisture content of Wood Members at time of fabrication.
- (o) Oven-dry specific gravity of Wood Members.
- (p) The number of Test Specimens tested.
- (q) Certification of calibration of the testing machine.
- (r) Mill certification data for the test steel coil heat number, or the results of *ASTM E8* tests of solid metal control specimens.

**ANNEX A5.2: DESIGN VALUE ADJUSTMENTS FOR SINGLE PASS ROLLER PRESSES (MANDATORY INFORMATION)**

**A5.2.1 Scope.**

The test procedures contained in Annex A5.2 provide a basis to assign Metal Connector Plate design values to joints assembled with roller presses by adjustment of design values determined with joints assembled with hydraulic presses.

**A5.2.2 Sampling.**

**A5.2.2.1 Number of Samples.**

Five matched specimen pairs shall be tested for each plate type, property (wood/plate orientation), roller type and diameter, and Species Combination evaluated.

**A5.2.2.2 Matched Test Specimen Pairs.**

Each specimen pair shall consist of one joint with plates embedded with a hydraulic press and one matching joint with plates embedded with a roller press. Each 2x4 (38 x 89 mm) Wood Member selected for matched specimen sampling shall be coded (identified) as to member number, and whether it is used with roller pressed plates or hydraulically pressed plates.

**A5.2.2.3 Materials.**

All materials shall be matched between joints within each specimen pair. Plates used within a specimen pair shall be typical of production, shall be of identical sizes produced from the same solid steel coil or sheet stock, and shall comply with Section 5.2.2. Lumber within a specimen pair shall be cross-matched between joints in accordance with Figure A5.2-1 and shall satisfy the requirements of Section 5.2.4.

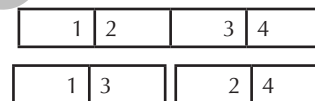

Cut Test Specimen in 4 pieces, sequentially number 1-4, and rejoin as shown for the test: 1-3 & 2-4.

**Figure A5.2-1**

**A5.2.3 Test Specimens Required.**

**A5.2.3.1 Property Evaluated.**

Tests shall be performed for lateral withdrawal resistance for  $V_{LRAA}$  (load parallel to grain, Metal Connector Plate Length parallel to load) (see Figure A5.2-2). Additional plate/wood orientations are not prohibited from being tested.

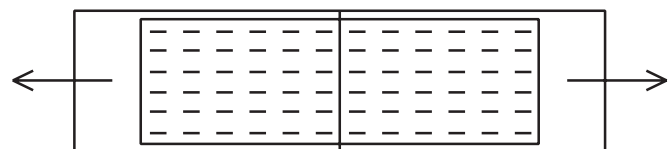

**Figure A5.2-2 Load parallel to grain, length parallel to load (VLRAA).**

**A5.2.3.2 Species.**

If results will be used to adjust hydraulic pressed test values determined with Species Combinations having published average oven-dry specific gravities that range both at or above 0.50, and at or below 0.49, then tests shall be

conducted with two Species Combinations: one species with a published average oven-dry specific gravity of 0.50 or greater, and one species with a published average oven-dry specific gravity of 0.49 or less. If results will be used to adjust hydraulic pressed test values determined with Species Combinations having published average oven-dry specific gravities that range only at or above 0.50, or only at or below 0.49, then tests shall be conducted with one Species Combination within the relevant specific gravity range. Published average specific gravities are from *ANSI/AWC NDS*. Additional Species Combinations are not prohibited from being tested.

#### A5.2.3.3 Plate Type.

Each plate type, for which roller pressed design values are to be determined, using a  $Q_R$  ratio, shall be tested in accordance with Annex A5.2.

#### A5.2.3.4 Roller Presses.

Roller embedment equipment used for fabricating test joints shall be typical of equipment used in manufacturing Trusses. The smallest roller diameter used in manufacturing Trusses shall be used in fabricating test joints. Additional roller diameters are not prohibited from being tested.

### A5.2.4 Test Specimen Fabrication.

#### A5.2.4.1 General.

Test Specimen fabrication shall satisfy the requirements of Section 5.2.6. Any jiggging required to maintain full wood contact across the joint shall be fully described in the test report. Any presetting techniques used to affix plates to the wood prior to roller pressing shall be typical of those used in the manufacture of Trusses and fully described in the test report.

#### A5.2.4.2 Roller Test Specimens.

All roller Test Specimens shall pass through the roller press with the length of the Test Specimen perpendicular to the length of the rollers (see Figure A5.2-3).

#### A5.2.5 Test Procedure.

##### A5.2.5.1 General.

Test procedures shall comply with the requirements of Section 5.2.8, except that tests of solid metal control specimens shall not be required.

##### A5.2.5.2 Test Specimen Pairs.

Both joints within a matched pair shall be tested at the identical number of days from their respective dates of fabrication.

##### A5.2.5.3 Tooth Withdrawal Failure.

All hydraulic pressed specimens shall fail by tooth withdrawal.

STEP 1. Attach 1 x 5 inch temporary restraining straps with 6 double headed nails to each side of the Wood Members at the joint to hold the Wood Members together and straight with matching marked ends.

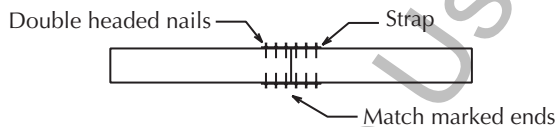

STEP 2. Set the Metal Connector Plate on the first face by striking opposite corners of the Metal Connector Plate once each with a hammer, turn the Test Specimen over and set the Metal Connector Plate on the opposite face in the same manner.

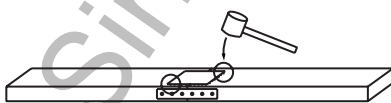

Note: This is one suggested method for fabricating roller pressed test specimens. Alternative methods, which will ensure that the Wood Members butt tightly against each other, and remain in line, are not prohibited from being used.

STEP 3. Feed the assembled test specimens through the roller press.

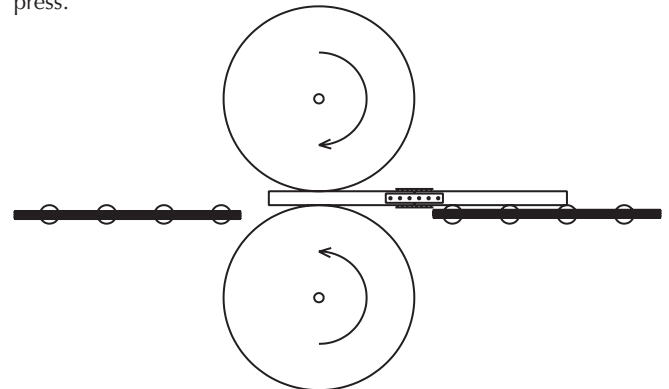

STEP 4. Carefully remove the temporary restraining straps.

Figure A5.2-3 Roller Plating.

### A5.2.6 Calculations.

#### A5.2.6.1 Strength Adjustment Ratios, ( $Q_R$ ).

Strength adjustment ratios for roller presses ( $Q_R$ ), per Section 5.2.5.2, shall be determined at Critical Slip levels and at ultimate levels, for each combination of plate type, roller press type and diameter, plate/wood orientation, and Species Combination selected for matched specimen testing, as follows:

- $Q_{R@Slip}$  shall be the average  $V_{LR}$  based on Critical Slip of the five roller pressed joints divided by the average  $V_{LR}$  based on Critical Slip of the five matched hydraulically pressed joints.  $Q_{R@Slip}$  shall be less than or equal to 1.0.
- $Q_{R@ultimate}$  shall be the average  $V_{LR}$  based on ultimate load of the five roller pressed joints divided by the average  $V_{LR}$  based on ultimate load of the five hydraulically pressed joints.  $Q_{R@ultimate}$  shall be less than or equal to 1.0.

#### A5.2.6.2 Plate Design Values.

Basic plate design values for plates embedded by roller presses shall be limited to the lower of the following two quantities:

$$(Q_{R@Slip})(V_{LRXX@Slip}) \quad (EA5.2-1)$$

$$(Q_{R@ultimate})(V_{LRXX@ultimate}) \quad (EA5.2-2)$$

where the  $V_{LRXX}$  terms above shall be from hydraulic pressed joint tests in accordance with Section 5.2.8 for the applicable Species Combination and plate/wood orientations to which the design values will be applied.

#### A5.2.6.3 $Q_R$ Application.

Where matched pair testing is performed at only the AA plate/wood orientation, resulting  $Q_R$  values shall be applied to all plate/wood orientations. Where only two Species Combinations of lumber in accordance with Section A5.2.3.2 are tested with matched pairs, the  $Q_R$  value resulting from the lower specific gravity Species Combination shall apply to all Species Combinations with average published specific gravities of 0.49 or lower, and the  $Q_R$  value resulting from the higher specific gravity Species Combinations shall apply to all Species Combinations with average published specific gravities of 0.50 or higher. Published average specific gravities are from *ANSI/AWC NDS*.

#### A5.2.7 Report.

The report on tests conducted in accordance with Annex A5.2 shall comply with Section 5.2.10, with the exception that the items in Section 5.2.10(r) shall not be required.

## 5.3 STANDARD METHOD OF TEST FOR STRENGTH PROPERTIES OF METAL CONNECTOR PLATES UNDER SHEAR FORCE

### 5.3.1 Scope.

Nail-on plates, meaning Metal Connector Plates without integral Teeth that are connected to the wood using only separately applied nails or other fasteners, shall be tested in accordance with this section using the same density of fasteners and presence (or lack thereof) of fasteners in Edge Distance zones as used in application of such plates on Trusses.

### 5.3.2 Metal Connector Plates.

#### 5.3.2.1 Test Specimen Selection.

Metal Connector Plates selected for Test Specimen fabrication shall be typical of production, and shall be manufactured in accordance with materials specified by the Metal Connector Plate manufacturer.

#### 5.3.2.2 Test Coil Steel.

The mechanical properties (yield, tensile, and elongation) of the test coil steel shall meet the requirements for the specified grade of steel for plate manufacture.

### 5.3.3 Solid Metal Control Specimens.

#### 5.3.3.1 Number of Samples.

A Solid Metal Control Sample shall be taken at each end of the section of each slit coil used to manufacture the Metal Connector Plates used in Section 5.3.4. A minimum of three solid metal control specimens shall be machined from each Solid Metal Control Sample.

#### 5.3.3.2 Control Specimen.

The solid metal control specimens shall be machined into standard rectangular Test Specimens with a reduced cross-section (see Figure 5.3-1).

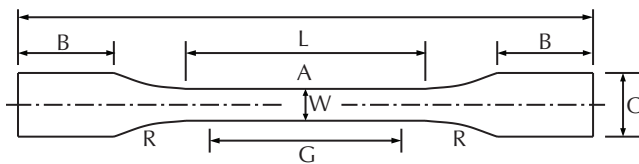

For dimensions, see *ASTM E8*.

Figure 5.3-1 Solid Metal Control Specimen.

### 5.3.4 Test Specimen Fabrication.

#### 5.3.4.1 General.

The Test Specimens shall be assembled with three Wood Members and four equal size Metal Connector Plates, one on each side of each joint interface, with the Metal Connector Plate Length ( $L_p$ ) inclined at an angle,  $\alpha$ , to the wood shear plane.

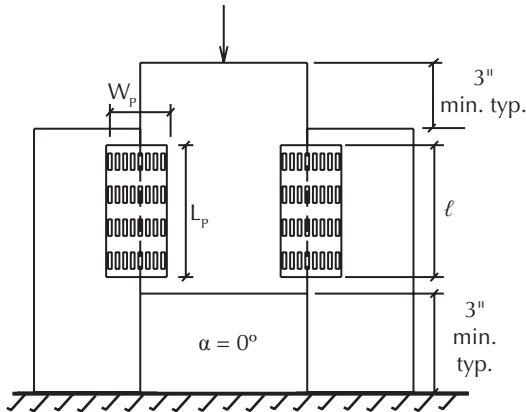

Figure 5.3-2 Zero Degree Orientation.

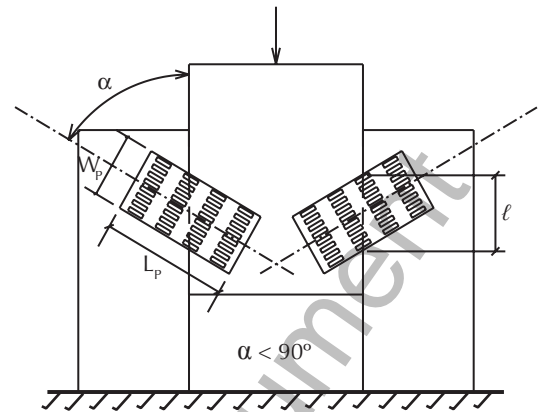

Figure 5.3-3 Acute Angle Orientation.

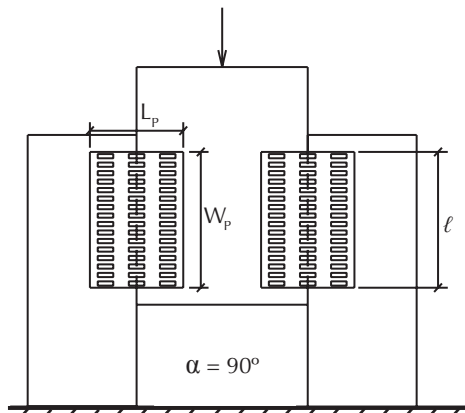

Figure 5.3-4 Ninety Degree Orientation.

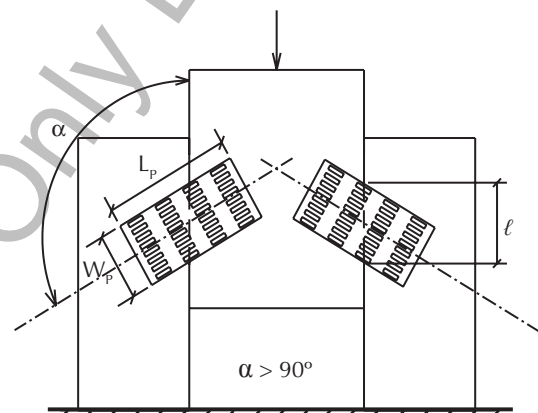

Figure 5.3-5 Obtuse Angle Orientation.

A zero degree angle is defined when the Metal Connector Plate Length ( $L_p$ ) is parallel to the wood joint (see Figure 5.3-2). Values for  $\alpha$  greater than zero are defined when the Metal Connector Plate Length is rotated counter-clockwise from the vertical (zero) position (see Figures 5.3-3 through 5.3-5).

#### 5.3.4.2 General Orientation.

The three Wood Members shall be placed so that the joint and lumber grain are in the same direction. The ends of the center Wood Member shall be 3 in. (76 mm) minimum above the corresponding ends of the outer Wood Members (see Figure 5.3-2), or as otherwise required to prevent any contact between the testing machine and the base of the center member or between the testing machine and the top of the exterior members.

#### 5.3.4.3 Less Than 90 Degree Orientation.

For orientations with  $\alpha$  less than 90 degrees, the centroid

of the Metal Connector Plate contact area on the outer Wood Members shall be above the centroid of the Metal Connector Plate contact area on the center Wood Member to ensure tension shear.

#### 5.3.4.4 Greater Than 90 Degree Orientation.

For orientations with  $\alpha$  greater than 90 degrees, the centroid of the Metal Connector Plate contact area on the outer Wood Members shall be below the centroid of the Metal Connector Plate contact area on the center Wood Member to ensure compression shear.

#### 5.3.4.5 Metal Connector Plate Length.

The Metal Connector Plates shall be of sufficient length to induce failure in the plate steel, rather than failure by tooth withdrawal. Where necessary, it shall be permitted to clamp the Metal Connector Plates, or otherwise firmly fasten them, a minimum of 2 in. (50 mm) from the joint to prevent withdrawal.

#### 5.3.4.6 Plate Embedment.

The Metal Connector Plates shall be firmly embedded, without removal of any Teeth, and shall be positioned with the minimum net section of the Metal Connector Plate directly over the shear plane.

#### 5.3.4.7 Embedment Procedure.

The embedment procedure shall be consistent with the method for embedding the Metal Connector Plates in the manufacturing process (i.e., by pressing or rolling). Over-pressing shall be avoided, so that the Metal Connector Plates do not embed into the Wood Member more than half the steel thickness.

#### 5.3.4.8 Joints.

The joints in the assembly shall be a close fit but not compressed.

#### 5.3.5 Test Specimens Required.

A minimum of three Test Specimens shall be tested at each of six specific Metal Connector Plate orientations,  $\alpha$ : 0°, 30°, 60°, 90°, 120°, and 150°.

#### 5.3.6 Test Procedure.

##### 5.3.6.1 General Measurements.

Before testing, measure all Metal Connector Plates to determine their gross width ( $W_p$ ) and length ( $L_p$ ) to the nearest 0.01 in. (0.3 mm), and minimum thickness ( $t$ ) to the nearest 0.0001 in. (0.002 mm). Take measurements at a minimum of three different locations on each Metal Connector Plate, using the average of three readings for the record.

##### 5.3.6.2 Angles.

For Metal Connector Plates to be tested at any orientation, angle  $\alpha$  shall be accurately measured for use in calculating the Metal Connector Plate Length along the shear line,  $\ell$ . When the angle of placement equals 0° and 90°,  $\ell$  equals  $L_p$  and  $W_p$ , respectively (see Figures 5.3-2 and 5.3-4).

##### 5.3.6.3 Set-Up.

Conduct tests on the Metal Connector Plate Test Specimens by placing the Test Specimen between and perpendicular to the testing machine platens and loading the Test Specimen in compression as shown in Figures 5.3-2 through 5.3-5. Apply the load concentrically throughout the tests at a uniform rate of movement of the platens of the testing machine so that the maximum load is reached in not less than 60 seconds.

#### 5.3.6.4 Testing Procedure for Solid Metal Control Specimens.

Conduct tests on the solid metal control specimens in accordance with *ASTM E8* procedures. Thickness shall be measured to the nearest 0.0001 in. (0.003 mm) and width to the nearest 0.001 in. (0.02 mm). Thickness of galvanized (or other) coating, if present, shall be measured or the coating shall be removed prior to thickness measurement. In lieu of coating measurement, the thicknesses given in Section 6.3.4.1.3 shall be permitted to be used for coating thickness.

#### 5.3.6.5 Maximum Loads.

For the Metal Connector Plates and solid metal control specimens, observe the maximum loads in pounds-force (or Newton).

#### 5.3.7 Calculations.

##### 5.3.7.1 Ultimate Tensile Strength - Control Specimen.

Calculate the ultimate tensile strength of the solid metal control specimen ( $F_{tc}$ ) by dividing the maximum tensile loads of each solid metal control specimen ( $P_{tc}$ ) by the cross-sectional area of the respective solid metal control specimen ( $A_{gc}$ ):

$$F_{tc} = \frac{P_{tc}}{A_{gc}} \quad (\text{E5.3-1})$$

The cross-sectional area of each solid metal control specimen is determined by multiplying the minimum thickness ( $t_{net}$ ) of the solid metal control specimen by the width of the solid metal control specimen ( $W$ ):

$$A_{gc} = t_{net} W \quad (\text{E5.3-2})$$

The  $F_{tc}$  values for all six, or more, solid metal control specimens from an individual coil of steel shall be averaged together, and the average value shall be used in Section 5.3.7.2.

##### 5.3.7.2 Theoretical Ultimate Shear Stress - Control Specimen.

Determine the theoretical ultimate shear stress of the solid metal control specimen ( $F_{sc}$ ) by multiplying the average ultimate tensile stress ( $F_{tc}$ ) by 0.577:

$$F_{sc} = 0.577F_{tc} \quad (\text{E5.3-3})$$

##### 5.3.7.3 Ultimate Shear Strength - Test Specimen.

For each Test Specimen, calculate the Metal Connector Plate ultimate shear strength ( $F_{sp}$ ) by dividing one-fourth of the maximum shear load carried by the Test Specimen

( $P_{sp}$ ) by the average gross cross-sectional area ( $A_{gp}$ ) of all four plates on the Test Specimen:

$$F_{sp} = \frac{P_{sp}}{4A_{gp}} \quad (\text{E5.3-4})$$

The gross cross-sectional area of each Metal Connector Plate ( $A_{gp}$ ) is obtained by multiplying the minimum thickness of the Metal Connector Plate ( $t_{net}$ ) by the calculated shear length of the Metal Connector Plate,  $\ell$ :

$$A_{gp} = t_{net}(\ell) \quad (\text{E5.3-5})$$

The three, or more,  $F_{sp}$  values calculated for each orientation shall be averaged together, and the average value shall be used in Section 5.3.7.4.

#### 5.3.7.4 Shear Strength Effectiveness Ratio.

Calculate the shear Effectiveness Ratio ( $R_s$ ), for each orientation of the Metal Connector Plate, by dividing the average Metal Connector Plate ultimate shear stress ( $F_{sp}$ ) for each orientation by the theoretical ultimate shear stress of the matched solid metal control specimen ( $F_{sc}$ ):

$$R_s = \left( \frac{F_{sp}}{F_{sc}} \right) = \frac{F_{sp}}{0.577 \times F_{tc}} \quad (\text{E5.3-6})$$

#### 5.3.8 Report.

The report shall include the following information:

- (a) Date of test and date of report.
- (b) Test sponsor and test agency.
- (c) Identification of Metal Connector Plates: manufacturer, model, type, material, finish, shape, dimensions, and other pertinent information. Metal Connector Plate material specifications shall include allowable tensile stress ( $F_{st}$ ) and allowable shear stress ( $F_{vs}$ ).
- (d) Complete description of test method and loading procedures used, if there are any deviations from the prescribed methods in this Standard.
- (e) Number of Test Specimens tested.
- (f) Rate of testing (crosshead speed or initial rate of load application).
- (g) Elapsed time of test.
- (h) All test data, including extrema and averages.

- (i) Shear Effectiveness Ratio for each individual Test Specimen and averages for all identical Test Specimens.
- (j) Description of type and path of failure.
- (k) Summary of findings.
- (l) Certification of calibration of the testing machine.
- (m) Results of the solid metal control specimen tests conducted per *ASTM E8*.

### 5.4 STANDARD METHOD OF TEST FOR STRENGTH PROPERTIES OF METAL CONNECTOR PLATES UNDER TENSION FORCES

#### 5.4.1 Scope.

Nail-on plates, meaning Metal Connector Plates without integral Teeth that are connected to the wood using only separately applied nails or other fasteners, shall be permitted to have tensile efficiency determined solely by geometric efficiency (see Section 5.4.1.1) if the nail holes, and any other perforations in the Metal Connector Plate, have smooth, rounded edges.

##### 5.4.1.1 Geometric Efficiency.

Geometric efficiency is the ratio of the net steel width at a cross-section to the gross steel width of the cross-section. Net steel width shall be the gross steel width minus the width removed by any holes in the cross-section.

##### 5.4.1.2 Chain of Holes Extending in Diagonal or Zigzag Line.

For a chain of holes extending in a diagonal or zigzag line, the net width of the cross-section shall be obtained by deducting from the gross width the sum of the diameters or slot dimensions of all holes in the chain and adding, for each space between holes in the chain, the quantity:  $s^2/4g$ .

where:

$s$  = longitudinal center-to-center spacing or pitch of any two consecutive holes

$g$  = transverse center-to-center spacing or gauge of any two consecutive holes

#### 5.4.2 Metal Connector Plates.

##### 5.4.2.1 Test Specimen Selection.

Metal Connector Plates selected for Test Specimen fabrication shall be typical of production and shall be



manufactured in accordance with materials specified by the Metal Connector Plate manufacturer.

**5.4.2.2 Test Coil Steel.**

The mechanical properties (yield, tensile, and elongation) of the test coil steel shall meet the requirements for the specified grade of steel for plate manufacture.

**5.4.3 Solid Metal Control Specimens.**

**5.4.3.1 Number of Samples.**

A Solid Metal Control Sample shall be taken at each end of the section of each slit coil used to manufacture the Metal Connector Plates used in Section 5.4.4. A minimum of three solid metal control specimens shall be machined from each Solid Metal Control Sample.

**5.4.3.2 Control Specimens.**

The solid metal control specimens shall be machined into standard rectangular Test Specimens with a reduced cross-section (see Figure 5.4-1).

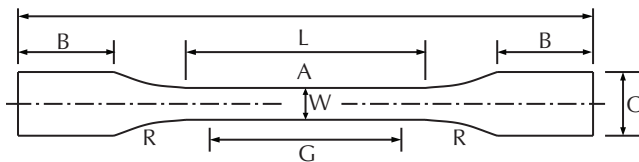

For dimensions, see ASTM E8.

**Figure 5.4-1 Solid Metal Control Specimen.**

**5.4.4 Test Specimen Fabrication.**

**5.4.4.1 Minimum Thickness.**

The Metal Connector Plate minimum thickness (t) shall be measured to the nearest 0.0001 in. (0.003 mm) before the Test Specimen is assembled.

**5.4.4.2 Test Specimen Assembly.**

If The Test Specimens shall be assembled as shown in Figures 5.4-2 and 5.4-3. The Metal Connector Plates shall be firmly embedded on both sides of the Test Specimen in the same manner as typically used in the manufacture of Trusses, and shall be positioned with the minimum net section of the Metal Connector Plate directly over the joint, even if this requires that the plate be positioned unsymmetrically.

**5.4.4.2.1 Non-Standard Test Specimens.**

If Test Specimens are built with the minimum net section not positioned over the joint, specific gravity of the wood members in each specimen shall be measured in accordance with sections 5.2.4.1 and 5.2.4.2 and included in the test report.

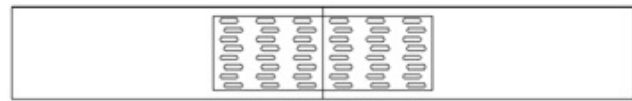

Non-standard test joint for steel tension parallel to slots (solid steel cross-section over the joint line)

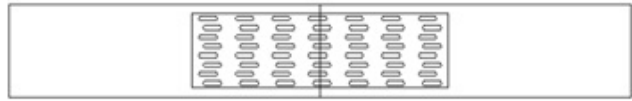

Standard test joint for steel tension parallel to slots (minimum cross-section over the joint line)

**Figure 5.4-4. Non-Standard and Standard Joints**

**5.4.4.3 Metal Connector Plate Length.**

The Metal Connector Plates shall be of sufficient length to induce a tensile or tearing failure of the net section steel, rather than lateral withdrawal failure in the Teeth. The Metal Connector Plates shall be permitted to be clamped a minimum of 2 in. (50 mm) from the joint to prevent lateral withdrawal of the Teeth, provided such clamping or fastening does not affect the tensile resistance of the Metal Connector Plate.

**5.4.5 Test Specimens Required.**

**5.4.5.1 Across Plate Width.**

For tests across the Metal Connector Plate Width, a minimum of three Test Specimens shall be assembled. The Metal Connector Plate shall be embedded in the Wood Members such that the Metal Connector Plate Width is perpendicular to the grain of the Wood Members (see Figure 5.4-2).

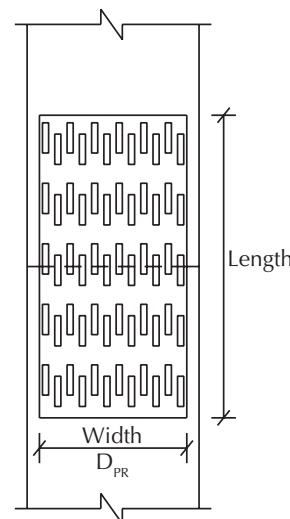
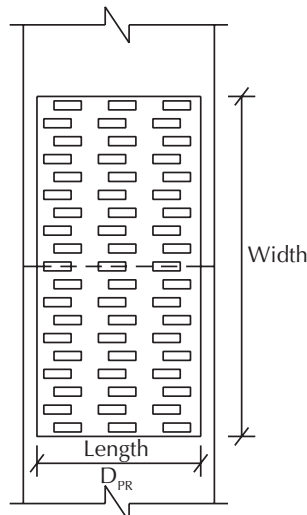

**Figure 5.4-2 Metal Connector Plate Width Perpendicular to Grain of Wood Members.**

**5.4.5.2 Across Plate Length.**

For tests across the Metal Connector Plate Length, a minimum of three Test Specimens of a single Metal Connec-

tor Plate Length shall be assembled. The Metal Connector Plate shall be embedded in the Wood Members such that the Metal Connector Plate Length is perpendicular to the grain of the Wood Member (see Figure 5.4-3).



**Figure 5.4-3 Metal Connector Plate Length Perpendicular to Grain of Wood Members.**

#### 5.4.6 Test Procedure.

##### 5.4.6.1 Measurements.

After assembly, measure the Metal Connector Plate gross dimension perpendicular to the Wood Member's grain ( $D_{PR}$ ) to the nearest 0.03 in. (0.08 mm). Take measurements at a minimum of three different locations on each Metal Connector Plate.

##### 5.4.6.2 Loading Procedure.

Conduct tests on the Metal Connector Plate Test Specimens by concentrically loading the Test Specimen in tension applied normal to the joint (parallel to the grain of the Wood Members) at a uniform rate of movement of the movable crosshead of the testing machine so that maximum load is reached in not less than 60 seconds.

##### 5.4.6.3 Testing Procedure for Solid Metal Control Specimens.

Conduct tests on the solid metal control specimens in accordance with *ASTM E8* procedures. Thickness shall be measured to the nearest 0.0001 in. (0.003 mm) and width to the nearest 0.001 in. (0.03 mm). Thickness of galvanized (or other) coating, if present, shall be measured or the coating shall be removed prior to thickness measurement. In lieu of coating measurement, the thicknesses given in Section 6.3.4.1.3 shall be permitted to be used for coating thickness.

#### 5.4.6.4 Maximum Loads.

For the Metal Connector Plates and solid metal control specimens, observe the maximum loads in pounds-force (or Newton).

#### 5.4.7 Calculations.

##### 5.4.7.1 Ultimate Tensile Strength - Test Specimen.

For each Test Specimen, calculate the Metal Connector Plate ultimate tensile strength ( $F_{tp}$ ) by dividing one-half of the maximum tensile load carried by the Test Specimen ( $P_{tp}$ ) by an average gross cross-sectional area ( $A_{gp}$ ) of the two Metal Connector Plates on the Test Specimen:

$$F_{tp} = \frac{P_{tp}}{2 \times A_{gp}} \quad (\text{E5.4-1})$$

The gross cross-sectional area of each Metal Connector Plate ( $A_{gp}$ ) is determined by multiplying the minimum thickness ( $t_{net}$ ) of the Metal Connector Plate by the gross dimension of the Metal Connector Plate perpendicular to the Wood Member's grain ( $D_{PR}$ ):

$$A_{gp} = t_{net} D_{PR} \quad (\text{E5.4-2})$$

The three, or more,  $F_{tp}$  values calculated for each test (across the Metal Connector Plate Width and across the Metal Connector Plate Length) shall be averaged together, and the average value for each test shall be used in Section 5.4.7.3.

##### 5.4.7.2 Ultimate Tensile Strength - Control Specimen.

Calculate the ultimate tensile strength of the solid metal control specimen ( $F_{tc}$ ) by dividing the maximum tensile loads of each solid metal control specimen ( $P_{tc}$ ) by the cross-sectional area of the respective solid metal control specimen ( $A_{gc}$ ):

$$F_{tc} = \frac{P_{tc}}{A_{gc}} \quad (\text{E5.4-3})$$

The cross-sectional area of each solid metal control specimen is determined by multiplying the minimum thickness ( $t_{net}$ ) of the solid metal control specimen by the width of the solid metal control specimen ( $W$ ):

$$A_{gc} = t_{net} W \quad (\text{E5.4-4})$$

The  $F_{tc}$  values for all six or more solid metal control specimens from an individual coil of steel shall be averaged together, and the average value shall be used in Section 5.4.7.3.

### 5.4.7.3 Tensile Effectiveness Ratio.

Calculate the tensile Effectiveness Ratio ( $R_t$ ), for both Metal Connector Plate Orientations - length perpendicular to grain and width perpendicular to grain - by dividing the average Metal Connector Plate ultimate tensile strength ( $F_{tp}$ ) for each orientation by the average ultimate tensile strength of the matched solid metal control specimen ( $F_{tc}$ ):

$$R_t = \frac{F_{tp}}{F_{tc}} \quad (\text{E5.4-5})$$

#### 5.4.7.3.1 Non-Standard Test Specimens.

Tensile Effectiveness Ratios determined from non-standard test specimens per section 5.4.4.2.1 shall be applicable only for plates in lumber of density equal to or greater than that tested and with plates positioned with the same cross-section on the joint as used in the Test Specimens.

### 5.4.8 Geometric Efficiency.

#### 5.4.8.1 Definition.

Geometric efficiency is defined in Section 5.4.1.1.

#### 5.4.8.2 Chain of Holes Extending in Diagonal or Zigzag Line.

For a chain of holes extending in a diagonal or zigzag line, the net width of the cross-section shall be obtained per Section 5.4.1.2.

### 5.4.9 Report.

The report shall include the following information:

- (a) Date of test and date of report.
- (b) Test sponsor and test agency.
- (c) Identification of Metal Connector Plates: manufacturer, model, type, material, finish, shape, dimensions, and other pertinent information. Metal Connector Plate material specifications shall include allowable tensile stress; also, identification of fasteners, such as type, size, quantity, and quality as well as the method of installing the Metal Connector Plates and their fasteners, used for load transfer in the case of nail-on plates, including the Nail Hole description.

- (d) Detailed drawings or photographs of test specimens before testing, if not fully described otherwise.
- (e) Complete description of test method and loading procedure used, if there are any deviations from the methods in this Standard.
- (f) Number of Test Specimens tested.
- (g) Rate of testing (crosshead speed or initial rate of load application).
- (h) Elapsed time of test.
- (i) All test data, including extrema and averages.
- (j) Tensile Effectiveness Ratios for each individual Test Specimen, and average values for all identical Test Specimens.
- (k) Description of type and path of failure.
- (l) Summary of findings.
- (m) Results of the solid metal control specimen test conducted per *ASTM E8*.
- (n) Certification of calibration of the testing machine.

## CHAPTER 6

# MATERIALS AND GENERAL DESIGN CONSIDERATIONS

### 6.1 GENERAL

#### 6.1.1 Structural Analysis.

##### 6.1.1.1 Mathematical Model.

Truss member axial forces, bending moments, and effective buckling lengths shall be based on a mathematical model of the Truss that closely approximates the geometry and properties of the Truss members and connections.

##### 6.1.1.2 Structural Analysis Method.

An accepted structural analysis method for analyzing statically indeterminate structures, such as the matrix stiffness method, shall be used to determine the design moments and axial forces for each Truss member.

#### 6.1.2 Truss Design Information.

Each Truss Design Drawing shall set forth, as a minimum, the information outlined in Sections 2.3.5.5 and any other requirements specified by the Building Designer. In addition, the following Truss design data shall be available:

- (a) Comprehensive design calculations, including the load combinations and conditions considered, along with the axial forces and moments resulting from these conditions;
- (b) The required number of effective Teeth for lateral resistance in each joint member contact area as determined in accordance with Section 8.3 using lateral strength design values derived per Section 5.2.9.2; and
- (c) The JSI for each joint, as calculated per Section 8.11.3.

### 6.2 LOADS

#### 6.2.1 General Loading Requirements.

In the absence of a governing Building Code, loads, forces, and combinations of loads shall be in accordance with accepted engineering practice for the geographical area under consideration and the appropriate sections of the most recent implemented *ASCE 7*.

#### 6.2.2 Loading Requirements for Metal-Plate-Connected Wood Trusses.

The following loading conditions shall apply to the design of metal-plate-connected wood Trusses.

##### 6.2.2.1 Non-Bearing Partitions.

The weight of non-bearing partitions shall be permitted to be ignored for Truss design purposes given the following conditions:

- (a) Trusses are spaced less than or equal to 24 in. (610 mm) on center;
- (b) All Top Chord panel lengths of supporting Trusses are less than or equal to 30 in. (760 mm) when the lumber is oriented in the flat direction;
- (c) Design live load of supporting Trusses results from a residential occupancy and is not less than 40 psf (1920 Pa); and
- (d) Partition weight is less than or equal to 60 pounds per linear foot (875 N/m).

##### 6.2.2.1.1 Non-Bearing Partition Weight Not Permitted to be Ignored.

If the conditions listed above do not exist, the Building Designer shall specify in the structural design documents the non-bearing partition loads that need to be applied to the Trusses.

##### 6.2.2.1.2 Non-Load Bearing Partitions Parallel to Supporting Trusses.

When non-load bearing partitions parallel to supporting Trusses are not located on or immediately adjacent to a Truss, the sub-floor shall be of adequate strength and stiffness to support the non-load bearing partition load, or other provisions shall be made by the Building Designer to distribute the non-load bearing partition weight to the supporting Trusses.

##### 6.2.2.2 Effect of Pitch.

Dead loads specified on a projected horizontal area basis shall have taken into account the effect of the pitch.

##### 6.2.2.3 Dead Loads for Determining Wind Uplift.

The dead load used in determining wind uplift shall not exceed the minimum expected actual weight of the materials, or 0.6 times the nominal design dead load if the

minimum expected actual weight of the materials is not known.

#### 6.2.2.4 Full- and Partial-Length Live Loading.

Live load on Trusses shall be considered for both cases of full-length loading and partial-length loading, where partial-length loading shall exclude the live load over the Truss in the area between a non-triangulated panel (i.e., open or mechanical chases in floor or roof Trusses) and the nearest bearing.

#### 6.2.2.5 Out-of-Plane Loading.

Trusses intended to transfer loads acting in a direction normal to the plane of the truss shall be designed to carry such loads. Segments of trusses shall be permitted to be used to transfer loads perpendicular to the plane of the truss for purposes of transferring load across joints occurring in the lateral force resisting system of the building as noted below without the need for any other consideration in the design of the truss.

##### 6.2.2.5.1 Loads through Chord-to-Chord Joints at Unblocked Diaphragm Joints.

Trusses transferring load at joints in diaphragms shall be limited to transferring the load associated with unblocked wood diaphragms. Any truss plates at chord-to-chord connections at such locations, such as peaks of trusses at ridgelines shall be no less than 3 inches in width.

### 6.3 DESIGN VALUES

Structural elements of trusses and similar components or elements designed in accordance with this Standard shall be designed to not exceed the adjusted design values specified herein. Adjusted design values shall be calculated using applicable ASD adjustment factors when the Allowable Stress Design (ASD) method is used and using applicable LRFD adjustment factors when the Load and Resistance Factor Design (LRFD) method is used, as shown by Table 6.3-1.

#### 6.3.1 Design Values for Solid Sawn Lumber.

Published design values ( $E$ ,  $E_{min}$ ,  $F_b$ ,  $F_c$ ,  $F_{c\perp}$ ,  $F_t$ , and  $F_v$ ) to be used in all engineering mechanics based equations for solid-sawn and finger-jointed lumber shall be certified by an accreditation body that complies with the U.S. Department of Commerce, *PS-20*. In lieu of a grade mark, a certificate of inspection issued by a lumber grading or inspection agency meeting the requirements of the building code shall be accepted.

Design of lumber chord and web members shall be based on dressed sizes as set forth by the U.S. Department of Commerce, *PS-20*. If other sizes or materials are used,

the net dressed size shall be stated in the design and used in the design calculations.

#### 6.3.2 Design Values for Structural Composite Lumber.

Design values for Structural Composite Lumber shall be approved by the authorities having Jurisdiction. The allowable tension stress value,  $F_t$ , for Structural Composite Lumber shall account for the length of lumber exposed to tensile stress. An allowable tension stress value established on the basis of a 20 ft. (6.096 m) length fully exposed to the maximum tensile stress shall be permitted to be used without further reduction for length effects for Structural Composite Lumber used as members subject to combined bending and tensile stresses.

#### 6.3.3 Design Values for Fasteners Other Than Metal Connector Plates.

Design values for fasteners other than Metal Connector Plates shall be in accordance with the *ANSI/AWC NDS*. Other fasteners shall be permitted when approved by the authorities having Jurisdiction.

#### 6.3.4 Design Values for Metal Connector Plates.

##### 6.3.4.1 Allowable Steel Stresses.

Allowable stresses in steel shall be applied to Effectiveness Ratios for Metal Connector Plates as determined per Chapter 5 of this Standard.

##### 6.3.4.1.1 Tensile Stress.

The allowable tensile stress,  $F_{st}$ , shall not exceed  $0.60F_y$  or  $0.50F_u$ .

##### 6.3.4.1.2 Shear Stress.

The allowable shear stress,  $F_{vs}$ , shall not exceed  $0.40F_y$  or  $0.30F_u$ .

##### 6.3.4.1.3 Design Thickness.

The design thickness ( $t_1$ ) of Metal Connector Plates shall be the minimum steel thickness specified ( $t$ ), less any specified coating thickness ( $t_c$ ), divided by 0.95, as shown in Equation E6.3-1.

$$t_1 = \frac{t - t_c}{0.95} \quad (\text{E6.3-1})$$

For galvanized steel, coating thickness deductions ( $t_c$ ) shall be:

G185	0.0031 in. (0.078 mm)
G90	0.0015 in. (0.038 mm)
G60	0.0010 in. (0.025 mm)
Electrolytic	0.0003 in. (0.008 mm)

Table 6.3-1 Applicability of Adjustment Factors.

		ASD Only	ASD and LRFD									LRFD Only		
		Load Duration Factor	Wet Service Factor	Temperature Factor	Flat Use Factor	Incising Factor	Repetitive Member Factor	Buckling Stiffness Factor	Bearing Area Factor	Bending Capacity Mod. Factor	Quality Control Factor	Format Conversion Factor ( $K_F$ )	Resistance Factor ( $\Phi$ )	Time Effect Factor
<b>Wood Member Properties</b>														
$F'_b = F_b$	x	$C_D$	$C_M$	$C_t$	$C_{fu}$	$C_i$	$C_r$	-	-	$K_m$	-	2.54	0.85	$\lambda$
$F'_t = F_t$	x	$C_D$	$C_M$	$C_t$	-	$C_i$	$C_r$	-	-	-	-	2.70	0.80	$\lambda$
$F'_v = F_v$	x	$C_D$	$C_M$	$C_t$	-	$C_i$	-	-	-	-	-	2.88	0.75	$\lambda$
$F'_{c\perp} = F_{c\perp}$	x	-	$C_M$	$C_t$	-	$C_i$	-	-	$C_e$	-	-	1.67	0.90	-
$F'_c = F_c$	x	$C_D$	$C_M$	$C_t$	-	$C_i$	$C_r$	-	-	-	-	2.40	0.90	$\lambda$
$E' = E$	x	-	$C_M$	$C_t$	-	$C_i$	-	-	-	-	-	-	-	-
$E'_{min} = E_{min}$	x	-	$C_M$	$C_t$	-	$C_i$	$C_r$	$C_T$	-	-	-	1.76	0.85	-
<b>Metal Connector Plate Properties</b>														
$V'_{LR} = V_{LR}$	x	$C_D$	$C_M$	-	-	$C_i$	$C_r$	-	-	-	$C_q$	3.32	0.65	$\lambda$
$F_s' = F_s$	x	-	-	-	-	-	-	-	-	-	-	See Below	See Below	-
-Based on $F_y$ for Tension	-	-	-	-	-	-	-	-	-	-	-	1.67	0.90	-
-Based on $F_u$ for Tension	-	-	-	-	-	-	-	-	-	-	-	2.00	0.75	-
-Based on $F_y$ for Shear	-	-	-	-	-	-	-	-	-	-	-	1.44	0.95	-
-Based on $F_u$ for Shear	-	-	-	-	-	-	-	-	-	-	-	1.92	0.70	-

Notes: Size factors not identified herein, or other factors mentioned herein but not explicitly assigned a variable within this Standard such as adjustments per section 6.4.9 are not intended to be excluded by this Table. Differences in this table from similar information in comparable design documents, such as the AWC NDS and AISI NASPEC, are intentional due to the content of this standard; see TPI 1 Commentary on this section for further information.

For aluminum-zinc alloy coated steel, coating thickness deduction ( $t_c$ ) for designation AZ50 shall be 0.002 in. (0.05 mm). These deductions are the total for both sides.

**6.3.4.2 Allowable Lateral Resistance Stresses.**

Allowable stresses for lateral resistance shall be determined in accordance with the procedures of Chapter 5 of

this Standard.

**6.4 ADJUSTMENTS TO DESIGN VALUES**

**6.4.1 Load Duration Factor ( $C_D$ ) – for ASD only.**

**6.4.1.1 Applicability.**

For ASD, design values shall be permitted to be adjusted

for load duration conditions in accordance with this section, unless otherwise specified by the authorities having Jurisdiction. The Building Designer shall be permitted to reduce the load duration factor when the expected load durations are greater than the assumed durations in Section 6.4.1.3.

#### 6.4.1.2 Design Values Affected.

Adjustments for load duration apply to all lumber and plate lateral resistance (tooth holding) Design Values, with the exception of modulus of elasticity ( $E$ ) and compression perpendicular to grain ( $F_{c\perp}$ ).

#### 6.4.1.3 Method.

The adjustment for load duration shall be accomplished by multiplying the design value by the appropriate  $C_D$  factor as shown in Table 6.4-1.

**Table 6.4-1 Load Duration Factor ( $C_D$ ) for Load Durations.**

Load Duration	$C_D$
Permanent	0.90
Normal - 10 Years duration	1.00
Snow - 2 Months duration	1.15
Construction - 7 Days duration	1.25
Wind & Earthquake - 5-10 minutes	1.60
Impact*	2.0

\* For FRT and pressure-preservative lumber and all connections subject to an impact load, the duration of load factor shall not exceed 1.6.

#### 6.4.1.4 Load Combinations.

For combinations of loads with different durations, the load duration factor,  $C_D$ , for the shortest duration load that is part of that load combination shall apply for that entire load combination.

### 6.4.2 Repetitive Member Increase ( $C_r$ ).

#### 6.4.2.1 Definitions and Conditions for Use.

Repetitive member design values apply to all Truss chord members where three or more Trusses are positioned side by side, are in contact, or are spaced no more than 24 in. (610 mm) on center and are joined by roof sheathing, flooring, gypsum, or other load distributing elements attached directly to the chords, as follows:

- (a) For solid sawn lumber members to which structural wood sheathing is mechanically attached: use the repetitive member design value listed in the recognized lumber grading rules, or a 15 percent increase to  $F_b$  and 10 percent increase to  $F_c$ ,  $F_t$  and  $E_{min}$ .

- (b) For solid sawn lumber members to which structural wood sheathing is not attached: use the repetitive member design value listed in the recognized lumber grading rules, or a 10 percent repetitive member design value increase to  $F_b$ ,  $F_c$ ,  $F_t$  and  $E_{min}$ .

- (c) For Structural Composite Lumber: repetitive member design values shall be limited to no more than a 4 percent increase to  $F_b$  and no (zero) increase to other allowable design values.

#### 6.4.2.2 Limitations.

Single-ply and two-ply girder Trusses are not permitted to use the repetitive member increases outlined in Section 6.4.2.1.

### 6.4.3 Bending Capacity Modification Factor ( $K_m$ ).

The bending capacity modification factor,  $K_m$ , as stated in Table 6.4-2, shall be permitted to be applied to the bending design value,  $F_b$ , for solid sawn lumber.  $K_m$  must be applied with respect to the entire Truss.

Note:  $K_m$  shall equal 1 for chord material other than solid sawn lumber (e.g., structural composite lumber). It shall not be permitted to use  $K_m$  per Table 6.4-2 for a portion of a Truss and to not use  $K_m$  (effective  $K_m = 1$ ) for other portions of a Truss.

### 6.4.4 Flat Use Factor ( $C_{fu}$ ).

Flat use factor for solid sawn lumber,  $C_{fu}$ , as stated in Table 6.4-3, shall be permitted to be applied to the bending design value,  $F_b$ , of solid sawn lumber members when the member is subjected to bending about its weak axis. Otherwise,  $C_{fu}$  shall be taken as unity.

**Table 6.4-3 Flat Use Factor ( $C_{fu}$ ) for Lumber 2" Thick.**

Width (in.)	$C_{fu}$
2 & 3	1.0
4	1.1
5	1.1
6	1.15
8	1.15
10 & wider	1.2

### 6.4.5 Buckling Stiffness Factor ( $C_T$ ).

#### 6.4.5.1 Conditions for Use.

The buckling stiffness factor,  $C_T$ , shall be applied to  $E_{min}$ , and shall be determined using Section 6.4.5.2 when the following conditions in (a) through (d) are met:

Table 6.4-2 Bending Capacity Modification Factors.

$K_m$	Applicable Condition
$\left[ 1.31 + 0.12 \times \left( \frac{M_1}{M_2} \right) \right] \times \left( \frac{L_p}{d} \right)^{-\frac{1}{6}} \leq 1.3$	Compression chord members continuous over one or more panel points, and where $1.0 \leq \frac{M_1}{M_2} \leq 3.0$
$\left[ 2.20 - 0.53 \times \left( \frac{M_1}{M_2} \right) - 0.64 \times \left( \frac{M_1}{M_2} \right)^2 + 0.41 \times \left( \frac{M_1}{M_2} \right)^3 \right] \times \left( \frac{L_p}{d} \right)^{-\frac{1}{6}} \leq 1.3$	Compression chord members continuous over one or more panel points, and where $-1.0 \leq \frac{M_1}{M_2} \leq 1.0$
$1.67 \times \left( \frac{L_p}{d} \right)^{-\frac{1}{6}} \leq 1.3$	All other compression chord members

$L_p$  = Actual length of the member between adjacent panel points, in.

$d$  = Depth of the member between adjacent panel points, in.

$M_1$  = Maximum bending moment between panel points (not including panel points)

$M_2$  = Maximum of the two bending moments at the adjacent panel points

Note: The sign of the bending moments,  $M_1$  and  $M_2$ , are retained in determining  $K_m$ . When  $M_1$  is of the same sign as  $M_2$ , then one of either  $M_1$  or  $M_2$  will actually be a minimum bending moment for that panel (rather than a maximum).

- (a) The member size is 2x4 (38 x 89 mm) or smaller;
- (b) Continuous  $\frac{3}{8}$  in. (9.5 mm) or thicker wood structural panel sheathing is attached to the chord with fasteners of the type, size, and spacing as required;
- (c) The member is subjected to combined bending and axial compression; and
- (d) The Trusses are used under dry service conditions.

If these conditions are not met,  $C_T$  shall be taken as unity.

#### 6.4.5.2 Method.

When permitted in accordance with Section 6.4.5.1, the buckling stiffness factor ( $C_T$ ) shall be determined as follows:

$$C_T = 1 + \frac{2300 \times L'}{k \times E} \quad (\text{E6.4-1})$$

for wood seasoned to a moisture content of 19 percent or less at the time the sheathing is applied to the chord, or as:

$$C_T = 1 + \frac{1200 \times L'}{k \times E} \quad (\text{E6.4-2})$$

for wood that is unseasoned or partially seasoned at the time of sheathing attachment, where:

$L'$  = Effective buckling length in inches, but not greater than 96 in. (2440 mm)

and

$k = 0.82$  for  $COV_E \leq 0.11$  for machine stress rated or structural composite lumber

$= 0.75$  for  $COV_E \leq 0.15$  for machine evaluated lumber

$= 0.59$  for  $COV_E \approx 0.25$  for visually graded lumber

#### 6.4.6 Wet Service Factor ( $C_M$ ).

##### 6.4.6.1 Conditions for Use and Values.

When dimension lumber is used where moisture content



will exceed 19 percent for an extended time period, design values shall be multiplied by the appropriate wet service factors in Table 6.4-4, except as specified in Section 6.4.6.2.

**6.4.6.2 Exceptions.**

$C_M$  shall be taken as unity for  $F_b$  or  $F_c$  if the following conditions are met:

If  $(F_b)(C_{fu}) \leq 1150$  psi,  $C_M = 1.0$  for  $F_b$

If  $(F_c) \leq 750$  psi,  $C_M = 1.0$  for  $F_c$

**6.4.6.3 Moisture Content > 19% at the Time of Fabrication.**

Metal Connector Plates installed in lumber having a moisture content greater than 19 percent at the time of Truss fabrication shall have the lateral resistance value ( $V_{LR}$ ) multiplied by  $C_M$ .

**6.4.7 Temperature Factor ( $C_t$ ).**

For structural members that will experience sustained exposure to elevated temperatures up to 150 degrees Fahrenheit, the tabulated design values shall be multiplied by the temperature factors in Table 6.4-5.

**6.4.8 Incising Factor ( $C_i$ ).**

**6.4.8.1 Conditions for Use.**

Tabulated design values shall be multiplied by the incising factor,  $C_i$ , per the current edition of *ANSI/AWC NDS*, when structural sawn lumber is incised to increase penetration of preservatives with incisions cut parallel to grain, a maximum depth of 0.4 in. (10 mm), a maximum

length of  $\frac{3}{8}$  in. (9.5 mm), and a maximum density of incisions of 1100/ft<sup>2</sup> (11800/m<sup>2</sup>). Incising factors shall be determined by test or by calculation using reduced section properties for incising patterns exceeding these limits.

**6.4.8.2 Reductions for the Design of Metal Connector Plates.**

Reduction factors shall be used for design of Metal Connector Plates installed in incised lumber.

**6.4.9 Chemically Treated Lumber.**

**6.4.9.1 Fire Retardant Treated (FRT) Lumber.**

All FRT lumber used in Trusses shall be re-dried after treatment to 19 percent maximum moisture content at temperatures not to exceed 160°F (71°C). FRT lumber design values shall be developed from approved test methods and procedures that consider potential strength-reduction characteristics, including effects of elevated temperature and moisture. Design values shall be approved by the authorities having Jurisdiction.

**6.4.9.2 Metal Connector Plates Installed in FRT.**

Metal Connector Plates installed in lumber pressure-impregnated with fire retardant chemicals shall have the reductions for lateral resistance values specified by the FRT chemical manufacturer. The quality mark shall indicate that the design value adjustments are in accordance with either the FRT manufacturer’s specifications or based upon an approved method of investigation which takes into consideration the effects of the anticipated temperature and humidity of which the FRT will be subjected.

**Table 6.4-4 Wet Service Factor ( $C_M$ ).**

$F_b$	$F_t$	$F_v$	$F_{c\perp}$	$F_c$	E & $E_{min}$	$V_{LR}$
0.85	1.0	0.97	0.67	0.8	0.9	0.8

**Table 6.4-5 Temperature Factor,  $C_t$ .**

Design Values	In Service Moisture Conditions	$C_t$		
		$T \leq 100^\circ\text{F}$	$100^\circ\text{F} \leq T \leq 125^\circ\text{F}$	$125^\circ\text{F} < T \leq 150^\circ\text{F}$
$F_t, E, E_{min}$	Wet or Dry	1.0	0.9	0.9
$F_b, F_v, F_c, F_{c\perp}$	Dry	1.0	0.8	0.7
	Wet	1.0	0.7	0.5

Table 6.4-6 Quality Control Factor ( $C_q$ ).

Fabrication Tolerance	$C_q$
0%	1.00
5%	0.95
10%	0.90
15%	0.85
20%	0.80
25%	0.75
30%	0.70

Note: These are example fabrication tolerances for a given  $C_q$  factor. The actual  $C_q$  factor shall be based on the fabrication tolerance set by the Truss Manufacturer.

#### 6.4.9.3 Preservative Treated Lumber.

All preservative treated lumber used in Trusses re-dried after treatment shall be re-dried to 19 percent maximum moisture content at temperatures not to exceed 160°F (71°C). Design values for preservative treated lumber used in Trusses shall be developed from approved test methods and procedures that consider potential strength-reduction characteristics, including incising marks. Design values shall be approved by the authorities having Jurisdiction.

#### 6.4.10 Quality Control Factor ( $C_q$ ).

##### 6.4.10.1 Applicability to Design Values.

The quality control factor ( $C_q$ ) shall only apply to plate lateral resistance design values ( $V_{LR}$ ).

##### 6.4.10.2 Conditions for Use.

The  $C_q$  factor shall be based on the fabrication tolerance selected by the Truss Manufacturer outlined in their In-

Plant Quality Assurance Program per Section 3.2. Fabrication tolerance and resulting  $C_q$  factor are shown in Table 6.4-6. The  $C_q$  factor shall not exceed 1.00 in any case.

##### 6.4.10.3 Modified Fabrication Tolerance.

The Truss Designer shall be permitted to increase the  $C_q$  factor based on the fabrication tolerance selected by the Truss Manufacturer, on a joint-by-joint basis, where necessary to evaluate the design requirements for that joint. In such cases, the Truss Design Drawing shall indicate that the joint was designed using a modified fabrication tolerance.

#### 6.4.11 Load and Resistance Factor Design (LRFD)

For LRFD, reference design values shall be multiplied by the format conversion factor,  $K_{F2}$ , the resistance factor,  $\Phi$ , and the time effect factor,  $\lambda$ , as shown in tables 6.3-1 and 6.4-7, except that the format conversion factor shall not apply where LRFD reference resistances are determined

Table 6.4-7 Time Effect Factors,  $\lambda$  (LRFD Only).

Load Combination*	Time Effect Factor ( $\lambda$ )
1.4D	0.6
1.2D + 1.6L + 0.5(L <sub>r</sub> or S or R)	0.6
1.2D + 1.6(L <sub>r</sub> or S or R) + (L or 0.5W)	0.7 (when L is from storage)
	0.8 (when L is from occupancy)
	1.25 (when L is from impact**)
1.2D + 1.0W + L + 0.5(L <sub>r</sub> or S or R)	1.0
1.2D + 1.0E + L + 0.2S	1.0
0.9D + 1.0W	1.0
0.9D + 1.0E	1.0

Notes: \*Load combination and load factors consistent with ASCE 7-10 are listed for ease of reference. Nominal loads shall be in accordance with section 6.2.1.

\*\*Time effect factors greater than 1.0 shall not apply to connections or to structural members pressure-treated with water-borne preservatives or fire retardant chemicals.

in accordance with the reliability normalization factor method in ASTM D5457.

#### 6.4.12 Other Adjustment Factors.

Wood design stresses for dry lumber shall be permitted to be used for green lumber when the following three conditions are met:

- (a) Trusses shall be stored after fabrication and installed in an exposure with equilibrium moisture content conditions of 19 percent or less;
- (b) Appropriate reduction factors ( $C_M$ ) shall be used for design of fasteners installed prior to the drying of the lumber, including Truss plates, nails, joist hangers, and similar fasteners; and
- (c) Typical conditions in that geographical area permit drying of the lumber to 19% moisture content or less prior to the closing in of the structure.

### 6.5 CORROSIVE ENVIRONMENTS

#### 6.5.1 Recognized Coatings.

The following coatings are recognized as providing increased corrosion protection to Metal Connector Plates:

- (a) Epoxy-Polyamide Primer (SSPC-Paint 22).
- (b) Coal-Tar Epoxy-Polyamide Black or Dark Red Paint (SSPC-Paint 16).
- (c) Post-plate-manufacture hot dip galvanizing per *ASTM A153*.

#### 6.5.2 Application of Coating.

Embedded Metal Connector Plates shall be free of dirt and oil prior to coating application. If the coating is damaged prior to, or during Truss installation, such damage shall be alleviated before accessibility is impeded.

#### 6.5.3 Stress Corrosion Cracking.

Metal Connector Plates, including Types 304 and 316 stainless steel plates, shall not be exposed to swimming pool environments unless adequate provision is made to prevent stress corrosion cracking. In lieu of use of a stainless steel that is not susceptible to stress corrosion cracking, Trusses shall be separated from the pool environment by a vapor barrier and shall be separately ventilated from the pool environment.

### 6.6 USE OF METAL CONNECTOR PLATES IN CONVENTIONAL WALLS

#### 6.6.1 Conditions for Use.

Metal Connector Plates not less than 1 in. x 3 in. (19 x 64 mm) on each face shall be permitted in lieu of nails or staples to fasten the wood studs to the wood plates in conventional walls. The bottom plate of the wall shall be continuously supported along its length and the maximum wall height shall not exceed 24 in. (610 mm).

#### 6.6.2 Cutting and Notching.

The cutting and notching of members shall be permitted within the requirements detailed in the Building Code for any wall member.

## CHAPTER 7

### MEMBER DESIGN PROCEDURES

#### 7.1 SCOPE

Each member shall be designed in accordance with Chapter 7 of this Standard to resist all forces and bending moments determined in accordance with Section 6.1.1.

#### 7.2 EFFECTIVE BUCKLING LENGTHS

##### 7.2.1 Effective Buckling Lengths for Chord Members.

The effective buckling lengths ( $L'$ ) for chord members (see Figures 7.2-2 and 7.2-3) shall be determined by an accepted structural analysis method, such as multiplying the unbraced lengths by an effective length factor as described in Sections 7.2.1.1 and 7.2.1.2 for buckling in the plane of the Truss, and by an effective length factor of 1.0 for buckling out of the plane of the Truss.

##### 7.2.1.1 Chord Member Panels Not Subject to Sidesway.

Chord panels between panel points not subject to Sidesway, as shown in Figure 7.2-2, shall be permitted to use effective buckling lengths,  $L'$ , equal to  $K \times L$ , where  $K$  is calculated per Equation E7.2-1 and shall not be less than 0.65, except for interior panels of continuous chord members spanning at least five panels, for which  $K$  shall be no less than 0.55. Panel points not subject to Sidesway shall include only those panel points that are prevented from moving relative to one another by adequate restraint and bracing, as shown in Figure 7.2-2.

$$K = \left\{ (\pi^2 + 2 \times N_a) \times (\pi^2 + 2 \times N_b) / [(\pi^2 + 4 \times N_a) \times (\pi^2 + 4 \times N_b)] \right\}^{0.5} \quad (\text{E7.2-1})$$

where:

$$\pi = 3.1416$$

$$N_a = (4 \times E_a \times I_a / L_a) / (E_t \times I_t / L_t)$$

$$N_b = (4 \times E_b \times I_b / L_b) / (E_t \times I_t / L_t)$$

$E_t$  = MOE of chord member for which  $K$  is being determined

$I_t$  = Moment of inertia of chord member for which  $K$  is being determined

$L_t$  = Length of member for which  $K$  is being determined

$E_a$  = MOE of chord member adjacent to member for which  $K$  is being determined

$I_a$  = Moment of inertia of chord member adjacent to member for which  $K$  is being determined

$L_a$  = Length of chord member adjacent to member for which  $K$  is being determined

$E_b, I_b, L_b$  = The same as  $E_a, I_a, L_a$  except for the adjacent chord member to the opposed side of the member for which  $K$  is being determined. If there is no such adjacent chord member,  $N_b$  shall equal zero.

##### 7.2.1.2 Chord Member Panels Subject to Sidesway.

For the effective buckling length,  $L'$ , equal to  $K \times L$ , for chord member panels subject to Sidesway, such as Overhangs including those Overhangs where the Truss bearing is at the end of the Overhang (also known as a tray condition),  $K$  shall be no less than 2.1 for panels with deflected shapes having only a single direction of curvature and no less than 1.0 for members in panels with deflected shapes having two directions of curvature.

#### 7.2.2 Effective Buckling Lengths for Web Members.

##### 7.2.2.1 Buckling in the Plane of the Truss.

The effective buckling length of Web members for buckling in the plane of the Truss shall be 0.8 times the unbraced length with respect to the Web width,  $d_1$ , for Webs not subject to Sidesway. The Effective Buckling Length shall be 2.1 times the unbraced length with respect to the Web width,  $d_1$ , for Webs subject to Sidesway, where the unbraced length is the length of the Web between Truss joints. For Webs crossing more than two joints, each panel shall be considered and checked separately where a panel is the length of the Web between adjacent Truss joints. Webs subject to Sidesway include those Web panels that extend outside of triangulated portions of the Truss, such as Webs extended to bearings below the Bottom Chord, Webs extended above the Top Chord to form a parapet wall without attachment to another Web or chord at the upper end of the extended Web, and similar conditions (see Figures 7.2-1 and 7.2-3).

Member	Effective Dimension (d)	Effective Buckling Length (L')
Top Chord & Bottom Chord	$d_1$	see Section 7.2.1
	$d_2$	$L_u$
Web	$d_1$	$0.8L_w$
	$d_2$	$0.8L_u$ or $0.8L_w$

Note: Where sheathing or ceiling is nailed to a compression chord (either Top or Bottom), lateral support of the supported axis shall be assumed to be continuous and  $L'/d = L_u/d_2$  is neglected.

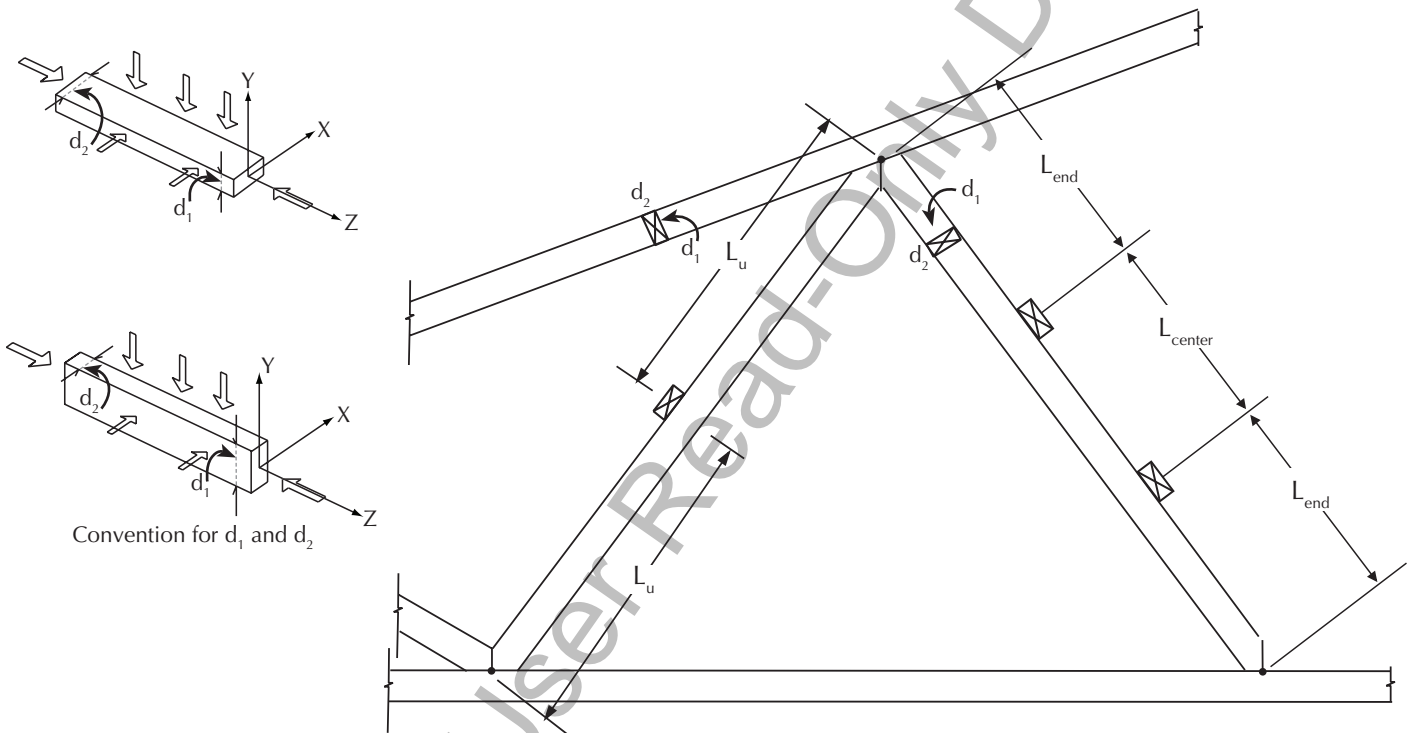

Figure 7.2-1 Unbraced Lengths for Out-of-Plane Buckling, Webs with 1 or 2 Lateral Restraint Locations.

**7.2.2.2 Buckling out of the Plane of the Truss.**

The effective buckling length for buckling out of the plane, meaning with respect to the Web thickness,  $d_2$ , shall be as follows (see Figures 7.2-1 and 7.2-3):

*For Webs that do not require any intermediate Lateral Restraint:*  $L' = 0.8 \times L_w$ , where  $L_w$  is the Web length.

*For Webs requiring one intermediate point of Lateral Restraint:*  $L' = 0.8 \times L_u$ , where  $L_u$  is the length between the lateral point of Lateral Restraint and the farthest Web end

from that restraint point.

*For Webs requiring two intermediate points of Lateral Restraint:*  $L' =$  greater of  $L_{center}$  or  $0.8 \times L_{end}$ , where  $L_{end}$  is the larger of the lengths between the point of Lateral Restraint and the adjacent Web end, and  $L_{center}$  is the length between the two points of Lateral Restraint.

Webs requiring three or more intermediate points of Lateral Restraint shall not be permitted.

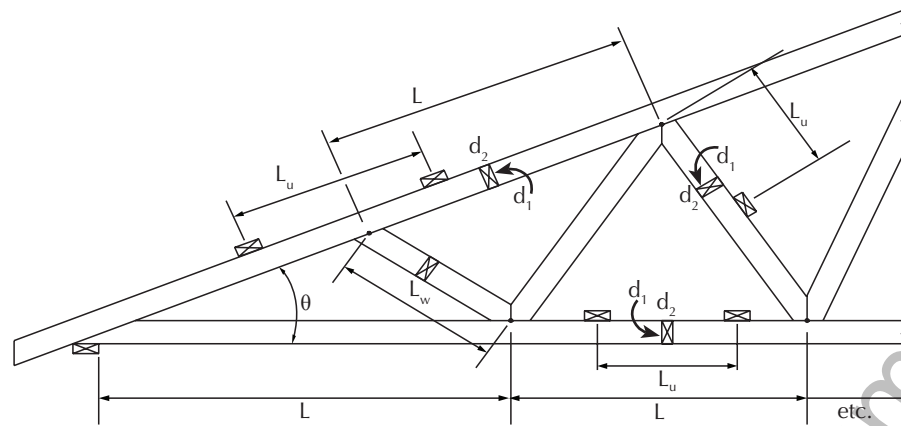

Figure 7.2-2 Unbraced Lengths for Out-of-Plane ( $L_u$ ,  $L_w$ ) and In-Plane ( $L$ ,  $L_w$ ) Buckling, Members Not Subject to Sidesway.

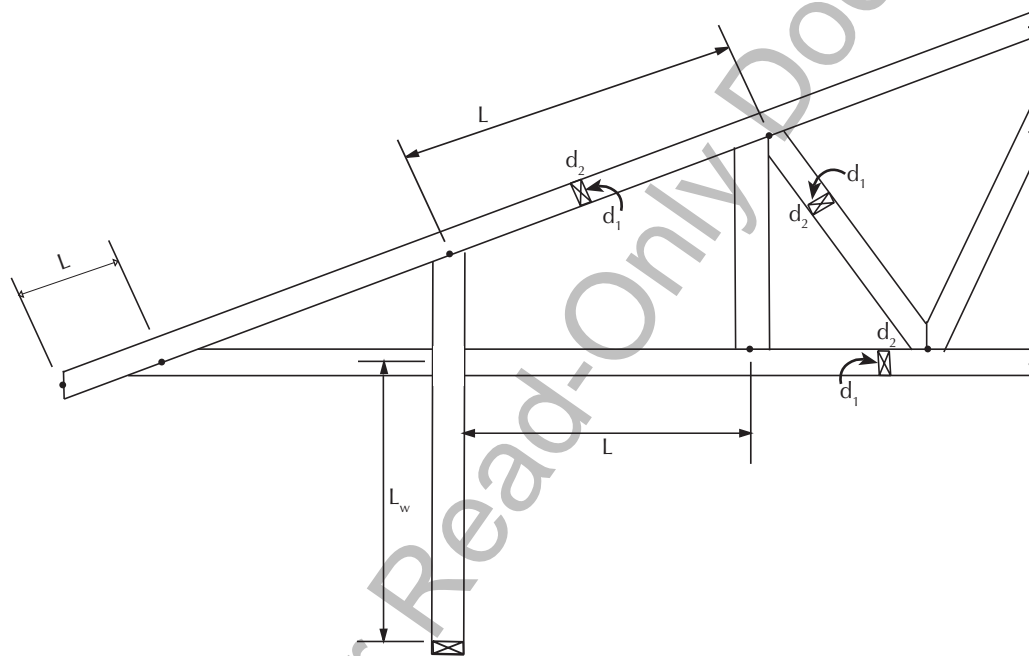

Figure 7.2-3 Unbraced Lengths for In-Plane ( $L$ ,  $L_w$ ) Buckling, Members Subject to Sidesway.

### 7.3 MEMBER DESIGN

$$f_t \leq F'_t \tag{E7.3-2}$$

#### 7.3.1 Tension Members.

Members subject to axial tension only shall be so proportioned that:

where:

$$f_t \leq F'_t \tag{E7.3-1}$$

$$f_c = P_c / A$$

where:

$$f_t = P_t / A$$

$$F'_t = F_t(C_D)(C_M)(C_t)(C_r)(C_i)$$

$$F'_c = F_c^* \times (K_F) \times \left[ \left( \frac{1 + \frac{F_{cE}}{F_c^*}}{2c} \right) - \sqrt{\left[ \frac{1 + \frac{F_{cE}}{F_c^*}}{(2c)} \right]^2 - \left( \frac{F_{cE}}{F_c^*} \right)} \right] \tag{E7.3-3}$$

#### 7.3.2 Compression Members.

Members subject to axial compression only shall be so proportioned that:

where:

$$c = 0.8 \text{ for sawn lumber} \\ = 0.9 \text{ for Structural Composite Lumber}$$

$K_r = 1.0$  for single ply members and determined per *ANSI/AWC NDS* for multiple ply members

$$F_c^* = F_c(C_D)(C_M)(C_t)(C_r)(C_i)$$

Except that  $F_c'$  shall be permitted to equal  $F_c^*$  at panel point checks for strong axis bending.

And the buckling design value,  $F_{cE}$ , is determined as:

The smaller of the following:

$$F_{cEx} = \frac{(0.822) \times E'_{min}}{\left(\frac{L'}{d_1}\right)^2}$$

$$F_{cEy} = \frac{(0.822) \times E'_{min}}{\left(\frac{L'}{d_2}\right)^2}$$

where:

$$E'_{min} = E_{min}(C_T)(C_t)(C_M)(C_i)(C_r)$$

### 7.3.3 Bending Members.

#### 7.3.3.1 Design Requirements.

Members subject to bending stresses in the plane of the Truss only shall be so proportioned that:

$$f_b \leq F_b' \tag{E7.3-4}$$

where:

$$f_b = M / S$$

**Note:** Reductions in section modulus (S) for tapered bending members, such as shown in Figures 7.3-2 or 7.3-3 shall be considered.

$$F_b' = F_b^* \times \left[ \left( \frac{1 + \frac{F_{bE}}{F_b^*}}{1.9} \right) - \sqrt{\left( \frac{1 + \frac{F_{bE}}{F_b^*}}{3.61} \right)^2 - \left( \frac{F_{bE}}{F_b^*} \right)} \right]$$

$$F_b^* = F_b(C_D)(C_M)(C_t)(C_r)(C_{fu})(C_i)(K_m)$$

And the buckling design value,  $F_{bE}$ , is determined, when  $d_1$  is greater than  $d_2$ :

$$F_{bE} = \frac{(1.20) \times E'_{min}}{\left[ \frac{L_e \times d_1}{d_2^2} \right]}$$

where:

$$E'_{min} = E_{min}(C_T)(C_t)(C_M)(C_i)(C_r)$$

$$\sqrt{\frac{L_e \times d_1}{d_2^2}} < 50$$

And the effective span length,  $L_e$ , for bending members is determined as follows:

$$L_e = 2.06L_u \quad \text{when } L_u / d_1 < 7$$

$$L_e = 1.63L_u + 3d_1 \quad \text{when } 7 \leq L_u / d_1 \leq 14.3$$

$$L_e = 1.84L_u \quad \text{when } L_u / d_1 > 14.3$$

#### 7.3.3.2 $L_u$ Value When Depth Exceeds Breadth.

When the depth of a bending member,  $d_1$ , exceeds its breadth,  $d_2$ , lateral support shall be provided at points of bearing to prevent rotation or lateral displacement at those points. When intermediate support is provided by purlins or bracing, connected so that they prevent lateral displacement of the loaded edge of the bending member, the unsupported length,  $L_u$ , shall be the maximum spacing between purlins or bracing at the top (loaded) edge of the chord member (see Figure 7.2-2).

#### 7.3.3.3 $L_u$ Not Required When Depth Does Not Exceed Breadth.

For members where depth,  $d_1$ , does not exceed breadth,  $d_2$ ,  $F_b'$  shall be equal to  $F_b^*$ .

#### 7.3.3.4 Fully Supported Bending Members.

When the loaded edge of a bending member is supported throughout its length by continuous sheathing to prevent its lateral displacement, and the ends at points of bearing have lateral support to prevent out-of-plane rotation, the member shall be considered fully supported, and  $F_b'$  shall be equal to  $F_b^*$ .

#### 7.3.3.5 Bottom Chord Bending Members.

When the Bottom Chord member of a Truss has a depth-to-thickness ratio (i.e.,  $d_1/d_2$ , based on nominal

dimensions) not exceeding 5 to 1, is spaced no more than 2 ft. (61 cm) on center, is braced throughout its length by an approved sheathing material, such as gypsum board or wood structural panels installed directly to the Bottom Chord of the Truss and fastened in accordance with *ASTM C840* or governing Building Codes or standards,  $F_b'$  shall be equal to  $F_b^*$ .

**7.3.3.6 Panel Point Moment Region at the Heel.**

For the panel point moment region at the heel of a Truss, when the bearing is under the Bottom Chord and within the scarf of the heel joint, the allowable design value for bending shall be permitted to be increased 30 percent (see Figure 7.3-1) for solid sawn lumber and 10 percent for Structural Composite Lumber, provided that  $K_m$  is set equal to 1.0 and not calculated per the equations in Table 6.4-2. This region shall be limited to no more than 2 times the chord depth as measured along the Top and Bottom Chords from the point of maximum moment.

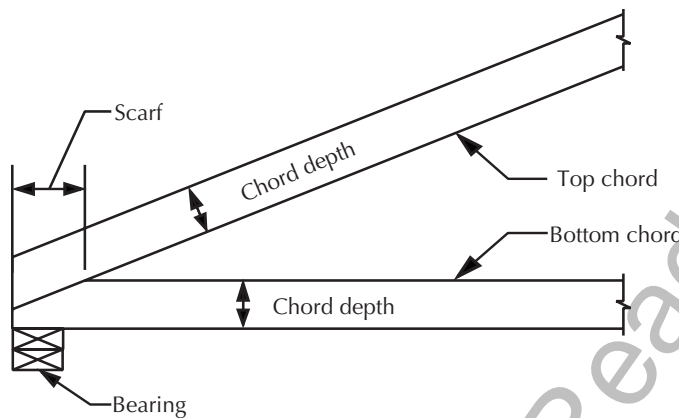

**Figure 7.3-1 Heel Detail.**

**7.3.3.7 Composite Action of Multiple Layers.**

Bending members consisting of multiple layers that are not glued-laminated or otherwise connected to assure composite action shall be designed assuming the layers are separate with no composite action other than resulting from the discrete connections connecting the layers. For bending members consisting of two layers that are connected with Metal Connector Plates at intervals not exceeding 30 in. (76 cm), moment of inertia and section modulus shall be permitted to be determined as 60 percent and 70 percent, respectively, of the moment of inertia and section modulus for the fully composite member.

When multiple layers consist of differing grades, a transformed section based on assigned (grade) MOE values shall be permitted to be used in calculating the moment of inertia and section modulus properties of the fully composite member. When multiple layers consist of differing grades and/or sizes, the stress checks required by this standard shall be performed for each individual layer

using the assigned design stresses for that layer's grade and size.

**7.3.4 Combined Bending & Tension.**

Members subject to both bending and axial tension shall be so proportioned that:

$$\frac{f_t}{F_t'} + \frac{f_b}{F_b^*} \leq 1.00 \tag{E7.3-5}$$

and

$$f_b - f_t \leq F_b' \tag{E7.3-6}$$

**7.3.5 Combined Bending & Compression.**

**7.3.5.1 Design Requirements.**

Members subjected to a combination of bending about one or both principal axes and axial compression shall be so proportioned that:

$$\left( \frac{f_c}{F_c'} \right)^2 + \left[ \frac{f_{bx}}{F_{bx}'} \times \left( 1 - \frac{f_c}{F_{cEx}} \right) \right] + \frac{f_{by}}{F_{by}'} \times \left[ 1 - \frac{f_c}{F_{cEy}} - \left( \frac{f_{bx}}{F_{bEx}} \right)^2 \right] \leq 1.00 \tag{E7.3-7}$$

where:

$$f_c < F_{cEx}$$

$$f_c < F_{cEy}$$

$$f_{bx} < F_{bEx}$$

$F_c'$ ,  $F_{cEx}$ , and  $F_{cEy}$  shall be based on the controlling buckling design value determined from Section 7.3.2, and  $F_{bEx}$  shall be calculated as shown in Section 7.3.3.

$F_{bx}'$  and  $F_{by}'$  are the allowable Design Values for bending in the plane of the Truss and out of the plane of the Truss, respectively.  $F_{bx}'$  shall be calculated as  $F_b'$  as shown in Section 7.3.3, and  $F_{by}'$  shall be calculated as  $F_b'$  in Section 7.3.3 except with the following modifications:  $d_2$  and  $d_1$  shall be reversed in all occurrences,  $L_u$  shall be the distance between adjacent panel points, and Sections 7.3.3.4 and 7.3.3.5 shall not apply.

At a panel point, the quantity  $[1 - f_c/F_{cEx}]$  shall be re-



placed by 1.

**7.3.5.2 Chord Members Continuously Braced.**

Chord members that are braced throughout their length by continuous sheathing need only be checked per Section 7.3.5 for buckling within the plane of the Truss. Hence  $F'_c$  shall be based upon  $L'/d$ , where  $d$  is equal to  $d_1$  in Figure 7.2-1.

**7.3.5.3 Chord Members Not Continuously Braced.**

Chord members that are not continuously braced throughout their length shall be checked per Section 7.3.5 for both buckling within the plane of the Truss and buckling within a plane perpendicular to the plane of the Truss. For buckling in the plane perpendicular to the Truss,  $F'_c$  shall be determined based upon  $L'/d$ .

where:

$$L' = L_u$$

$$d = d_2 \text{ (as shown in Figure 7.2-1)}$$

**7.3.6 L'/d Ratios for Compression & Tension Members.**

Unless design calculations are performed to account for the interaction of axial compression with initial deformation of compression members due to warp or other causes, the maximum  $L'/d$  for long-term compression members shall not exceed 50, and the maximum  $L'/d$  for tension members subject to reversal of stress due to short term loads other than gravity loads, shall not exceed 80. For Chords and Webs, the effective buckling length shall be as shown in Section 7.2.

**7.3.7 Shear.**

**7.3.7.1 Design Requirements.**

Members subject to shear stress shall be so proportioned that:

$$f_v \leq F'_v \tag{E7.3-8}$$

$$f_v = \frac{3V}{2A}$$

where:

$$F'_v = F_v(C_D)(C_T)(C_M)(C_1)$$

**7.3.7.2 Tapered Bottom Chord Heel.**

For tapered Bottom Chord members at heel joints, a shear check is required when the projection point is closer to the end of the Truss than the Truss point, as illustrated

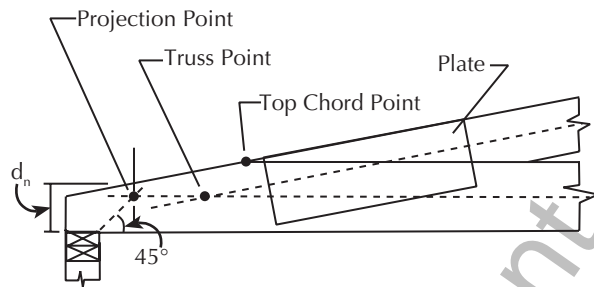

**Figure 7.3-2 Depth for Shear Check of Tapered Bottom Chord Heel.**

in Figure 7.3-2. The actual shear stress along-the-grain (horizontal) shall be calculated using the depth,  $d_n$ , at the projection point, a point at which a line initiating at the inside edge of the bearing and extending upward at an angle of 45 degrees to the length of the Chord intersects with the Bottom Chord centerline, as illustrated in Figure 7.3-2. If the Bottom Chord center line intersects the scarf cut before intersecting with the 45 degree line,  $d_n$ , is determined from where the 45 degree line intersects the scarf cut.

**7.3.7.3 Scarf Cut Bearings.**

The maximum shear load imposed from bearings shall not exceed the allowable shear load shown below for Wood Members that bear at an angle other than parallel to grain and with the bearing cut on the member extending beyond the inside face of the bearing, such as shown in Figure 7.3-3.

$$V' = (\frac{2}{3}) \times F'_v \times d_2 \times d_n \times (d_n/d_1)^2 \tag{E7.3-9}$$

where:

$d_n$  = Depth of the member measured perpendicular to the slope at the inside edge of the bearing

Other variables are as defined in previous sections.

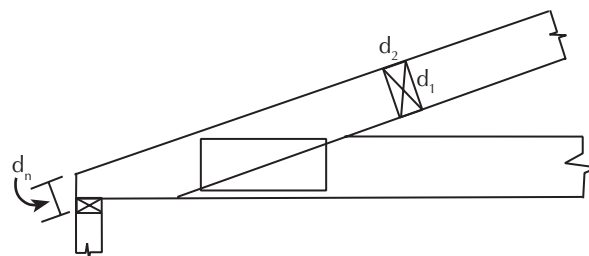

**Figure 7.3-3 Depth for Shear Check of Scarf Cut Bearing.**

**7.3.7.4 Use of Metal Connector Plates to Resist Shear.**

Metal connector plates are permitted to be used to resist the horizontal shear stress induced in chord members

subject to large shear forces (e.g., heel joints).

**7.3.8 Bearing Perpendicular to Grain.**

**7.3.8.1 Design Requirements.**

The stress induced in compression perpendicular to grain ( $f_{c\perp}$ ) at Reactions, joints, or from loads applied to members, shall be based on the net bearing area and shall not exceed the stresses derived using Equations E7.3-10 and E7.3-11:

$$f_{c\perp} \leq F_{c\perp}' \tag{E7.3-10}$$

$$f_{c\perp} \leq 0.3 \times E' \times (d_2/d_1)^2/20 \tag{E7.3-11}$$

where:

$$f_{c\perp} = R/A_b$$

$$F_{c\perp}' = F_{c\perp}(C_t)(C_M)(C_i)(C_b)(C_{plate})$$

$F_{c\perp}$  = Reference compression perpendicular to grain design value, psi

$$E' = E(C_t)(C_M)(C_i)$$

$E$  = Reference modulus of elasticity, psi  
(Note:  $C_T$  is not applicable for  $E'$  use in Equation E7.3-11)

$C_b$  = Bearing area factor per Section 7.3.8.2

$C_{plate}$  = Bearing plate increase factor per Section 7.3.8.3

$A_b$  = Net bearing area, in.<sup>2</sup> =  $\ell_b B$

$R$  = Force transferred through bearing area, lbs.

$\ell_b$  = Length of bearing area parallel to span of Truss, in.

$B$  = Width of bearing area perpendicular to span of Truss, in.

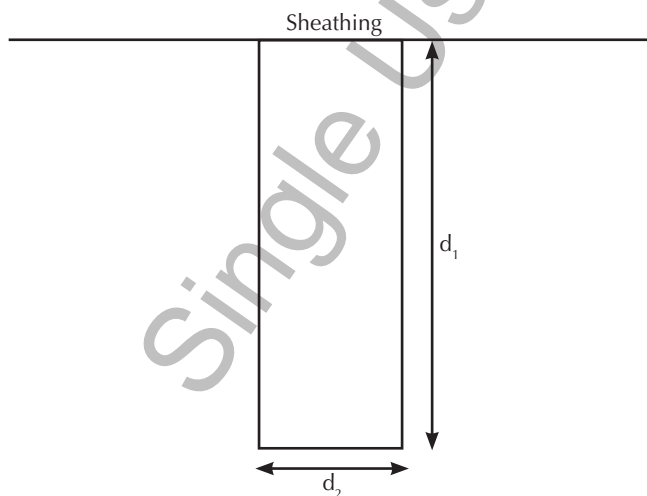

**Figure 7.3-4 Cross-Sectional In-Plane and Out-of-Plane Dimensions.**

(=  $d_2$  for Truss member unless bearing area is narrower than Truss)

$d_1, d_2$  = Cross-sectional in-plane and out-of-plane dimensions, respectively, of the Truss member being checked, modified as permitted below (see Figures 7.3-4 through 7.3-6)

**7.3.8.1.1  $d_2$ .**

The value of  $d_2$  in Equation 7.3-11 shall be permitted to equal the total thickness of a multiple-ply Truss provided the individual Truss plies are fastened to each other directly over the bearing with nails, screws or other fasteners at a spacing perpendicular to grain no greater than 4 in. (102 mm) and a spacing parallel to grain no greater than 4 in. (102 mm) for bearings exceeding 4 in. (102 mm) in length.

**7.3.8.1.2  $d_1$ .**

The value of  $d_1$  for use in Equation E7.3-11 shall equal the greatest value of the member depth that occurs perpendicular to the bearing surface when checking the member for the component of the bearing force that is imposed from the opposite edge of the member from the bearing surface (see Figure 7.3-5).

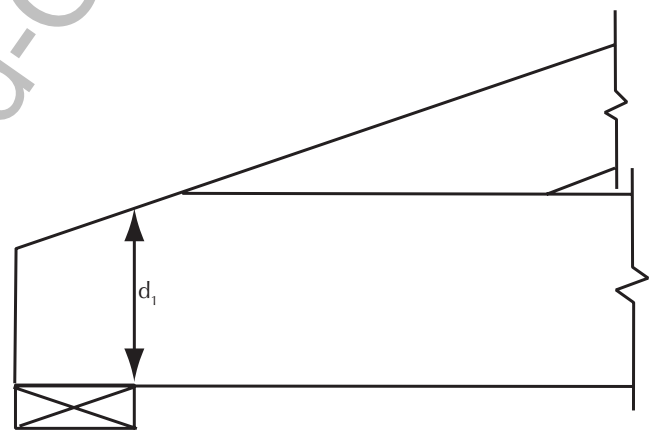

**Figure 7.3-5**

When such forces are imposed across multiple members, such as multiple chord members that are stacked or otherwise vertically laminated, such as at heels of Trusses,  $d_1$  shall be set equal to the sum of the dimensions of the stacked members (see Figure 7.3-6).

The value of  $d_1$  for use in Equation E7.3-11 shall equal one half of the greatest value of the member depth that occurs perpendicular to the bearing surface when checking the member for the component of the bearing force that is imposed from loads other than those from the opposite edge of the member from the bearing surface, such as loads carried as shear forces within the member being checked from lengths of that member adjacent to the bearing surface. These values of  $d_1$  shall be permitted

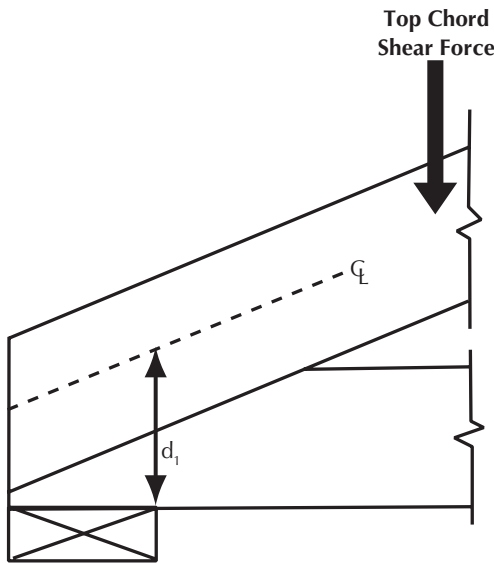

Figure 7.3-6

to be reduced to the distance between out-of-plane bracing when such bracing is present, including the following situations:

- (a) When the member subject to the bearing stress is fastened to a reinforcing member designed to prevent the bearing member from buckling,  $d_1$  shall be permitted to be reduced to the greatest perpendicular to grain spacing between fasteners or between the edge of the member and the nearest fastener.
- (b) When the member subject to the bearing stress is in full contact across its entire depth by confining members, such as by solid blocking, on both sides, then Equation E7.3-11 may be disregarded.

**7.3.8.2 Bearing Area Factor.**

For bearings less than 6 in. (152 mm) in length ( $\ell_b < 6$  in.) and not nearer than 3 in. (76 mm) to the end of the Truss member, the tabular design values in compression perpendicular to grain shall be permitted to be multiplied by the bearing area factor,  $C_b$ , in addition to any other applicable modification factors.

where:

$$C_b = \frac{\ell_b + 0.375}{\ell_b}$$

This equation gives the following bearing area factors,  $C_b$ , for the indicated bearing lengths:

Length of Bearing, $\ell_b$	3.5 in.	5.5 in.	6 in.+
Bearing Area Factor, $C_b$	1.11	1.07	1.00

**7.3.8.3 Bearing Plate Increase Factor.**

For compression perpendicular to grain loads bearing on a 1.5 in. (38 mm) wide face of a Truss member with a Truss plate on each adjacent normal face positioned with the nearest edge of the Truss plate no farther than 1/4 in. (6.5 mm) from the lumber edge common to both the 1.5 in. (38 mm) wide bearing face and the plated face, the tabular design value in compression perpendicular to grain shall be permitted to be multiplied by the bearing plate increase factor,  $C_{plate}$ , of 1.18 in addition to any other applicable modification factors.

**7.3.9 Bearing Parallel to Grain.**

**7.3.9.1 Design Requirements.**

The actual compressive stress parallel to grain,  $f_c$ , shall be based on the net bearing area and shall not exceed the allowable bearing design value parallel to grain,  $F_c^*$ . Values for  $F_c^*$  apply to end-to-end bearing of compression members provided there is adequate lateral support and the end cuts are accurately squared and parallel.

$$f_c \leq F_c^* \tag{E.7.3-12}$$

where:

$$F_c^* = F_c(C_D)(C_M)(C_t)(C_i)$$

**7.3.9.2 Additional Requirements.**

When  $f_c > 0.75 F_c^*$ , bearing shall be on a metal plate or strap, or on other equivalently durable, rigid, homogeneous material of sufficient stiffness to distribute the applied load. When a rigid insert is required for end-to-end bearing of compression members, it shall be equivalent to a 20 gauge metal plate or better, inserted with a snug fit between abutting ends. The rigid insert shall also be illustrated or specified on the Truss Design Drawing.

**7.3.10 Bearing at an Angle to Grain.**

The adjusted bearing design value at an angle,  $\theta$ , to grain, as shown in Figure 7.3-7, shall be calculated as follows:

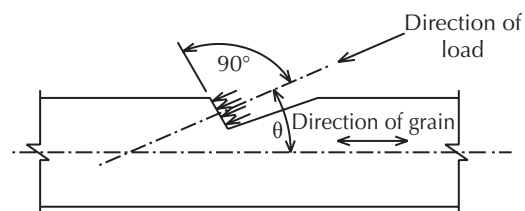

Figure 7.3-7 Load at an Angle,  $\theta$ , to the Grain.

**Table 7.4-1 Top Chord and Intermediate-Height Bearing Limits.**  
 (nominal 2 x 3 = 38 x 63 mm, 2 x 4 = 38 x 89 mm, 2 x 6 = 38 x 140 mm)

bearing Detail Figure	Number of Top Chords	End Vertical Web	Top Chords	Maximum Allowable R (lbs)	A (in)	B (in)	C (in)
7.4-1 (a)	1	1	4x2	600	1/2	1/8	1/8
7.4-1 (b)	2	1	4x2	1600	1/2	1/8	1/8
7.4-1 (b)	2	1	3x2	1150	1/2	1/8	1/8
7.4-1 (c)	2	0	4x2	1600	1/2	1/8	1/8
7.4-1 (c)	2	0	3x2	1150	1/2	1/8	1/8
7.4-1 (d)	2	0	4x2	1600	1/2	---	1/8
7.4-1 (d)	2	0	3x2	1150	1/2	---	1/8
7.4-1 (e)	1	0-1	4x2	1600	---	1/8	1/2
7.4-1 (f)	2	0-1	4x2	4000	---	1/8	1/2
7.4-2 (a)	1	1	2x4	1700	1/2	1/2	1/8
7.4-2 (a)	1	1	2x6*	2500	1/2	2	1/8
7.4-2 (b)	1	0	2x4	1700	1/2	1/2	1/8
7.4-2 (b)	1	0	2x6*	2500	1/2	2	1/8
7.4-2 (c)	1	0	2x4	2400	1/2	---	1/4
7.4-2 (c)	1	0	2x6*	4000	1/2	---	1/4
7.4-2 (d)	1	0	2x4	3200	---	1/2	1/2
7.4-2 (d)	1	0	2x6*	4000	---	2	1/2

\* or greater

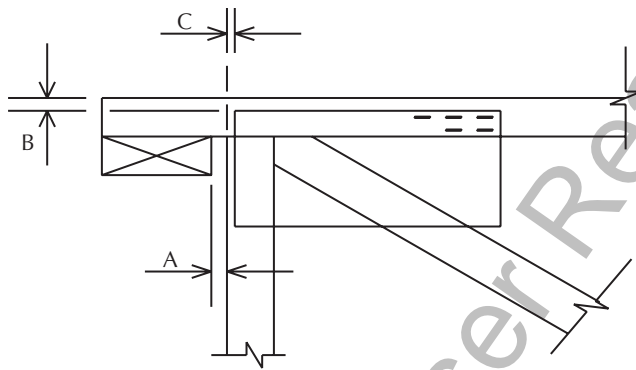

Figure 7.4-1(a)

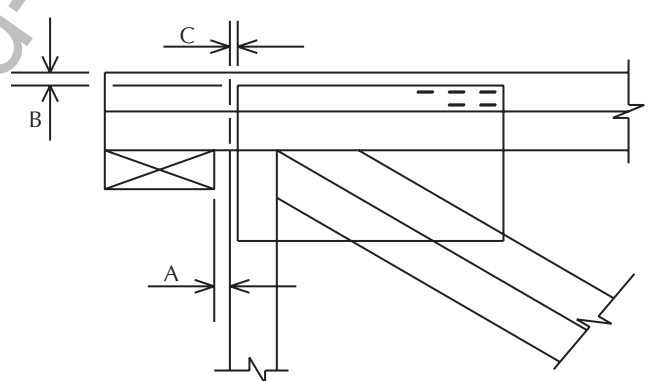

Figure 7.4-1(b)

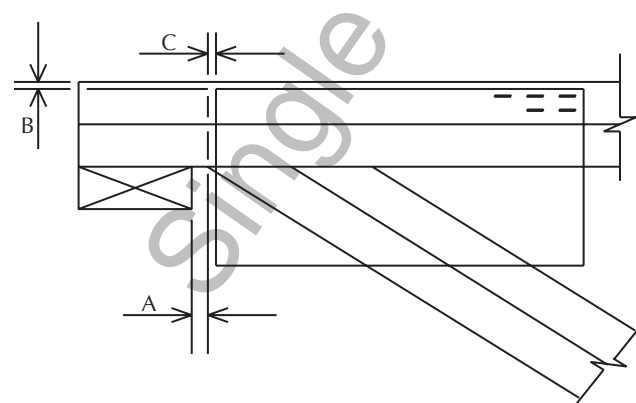

Figure 7.4-1(c)

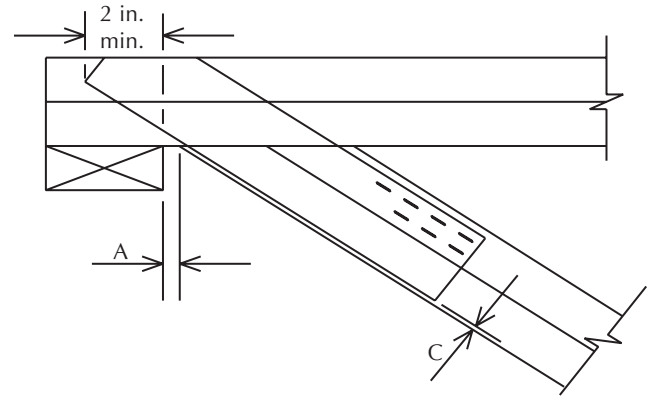

Figure 7.4-1(d)

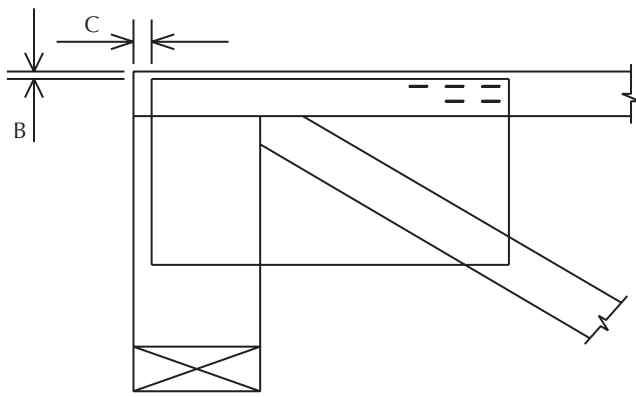

Figure 7.4-1(e)

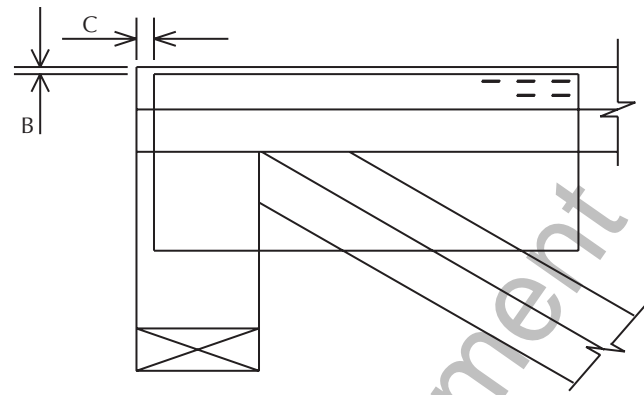

Figure 7.4-1(f)

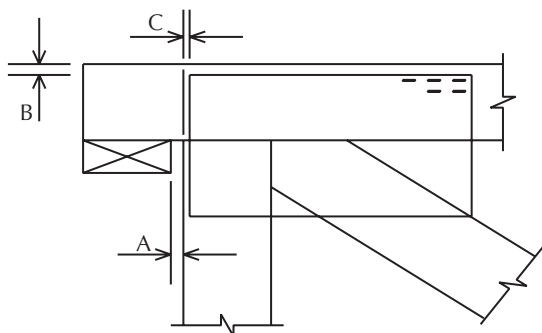

Figure 7.4-2(a)

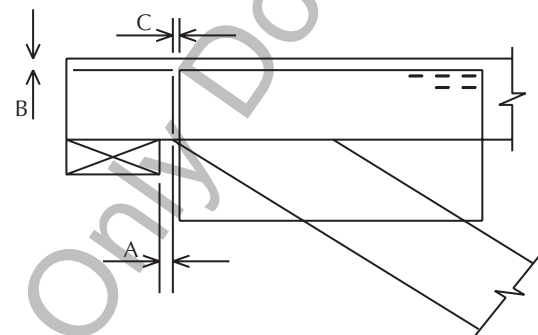

Figure 7.4-2(b)

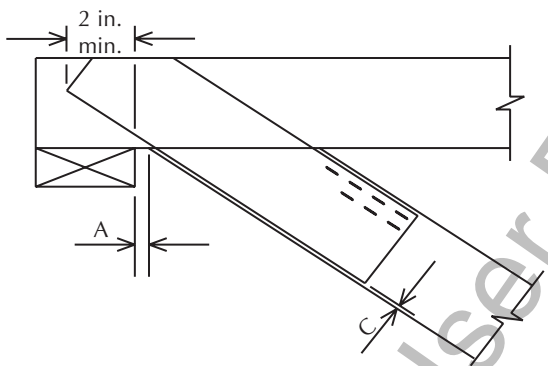

Figure 7.4-2(c)

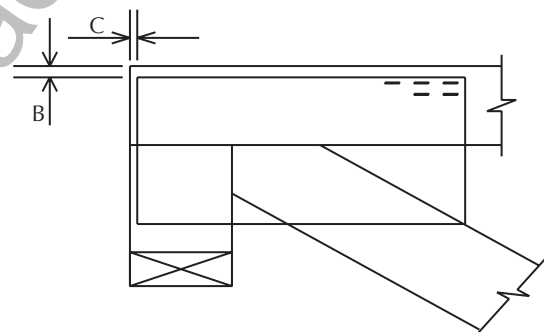

Figure 7.4-2(d)

$$F'_\theta = \frac{F_c^* \times F_{c\perp}'}{(F_c^* \times \sin^2 \theta) + (F_{c\perp}' \times \cos^2 \theta)} \quad (E7.3-13)$$

## 7.4 ALLOWABLE TRUSS REACTIONS

### 7.4.1 Minimum Length of Bearing.

Except where supported by mechanical fasteners such as nails or screws, or framing hardware such as hangers, all bearing supports that are at the end of a Truss shall provide no less than 1.5 in. (38 mm) of bearing length on wood or metal and not less than 3 in. (76 mm) of bearing

length on masonry or concrete unless approved by any Registered Design Professional.

The minimum length of the bearing shall not be less than that required by the allowable bearing stress.

### 7.4.2 Top Chord Bearing Parallel Chord Trusses.

Top Chord bearing parallel chord Trusses with a gap between the inside of the bearing and the first diagonal or vertical web exceeding 1/2 in. (13 mm) shall be designed considering effects of shear and bending on the extended chord. In all cases involving gaps that are equal to or less than 1/2 in. (13 mm) on Top Chord bearing Trusses and for

intermediate-height bearing Trusses, reaction at the bearings shall not exceed the limits shown in Table 7.4-1 for the configurations shown, unless otherwise established by test or alternate analysis method.

**7.5 GIRDER TRUSS DESIGN**

**7.5.1 General.**

A girder Truss is a Truss that carries concentrated loads imposed by another Truss or other structural framing, and shall be designed in accordance with Section 7.5.

**7.5.2 Girder Loading.**

**7.5.2.1 Application of Reactions onto Girder Trusses.**

Reactions,  $R_1$ , imposed by uniformly spaced members spaced at more than 34 in. (86 cm) on center shall be applied as concentrated loads. Conversion of Reactions imposed by uniformly spaced members spaced less than or equal to 34 in. (86 cm) on center to an equivalent uniform load is not prohibited.

**7.5.2.2 Applied Loads Based on the Most Critical Reaction.**

All load cases applied to the supported structural members, including unbalanced loads, which create critical stresses in the girder truss, shall be considered in the design of the girder truss.

**7.5.2.3 Load Continuous Across All Plies.**

If a structural member imposing a load on a girder is continuous across all plies, the load shall be considered to be equally distributed to all plies.

**7.5.2.4 Maximum Plies.**

The maximum number of plies shall be five, if the structural members imposing a load are attached to one side of the girder, or six, if the structural members imposing a load are attached to both sides of the girder.

**7.5.2.5 Location of the Applied Load.**

The design load shall be applied on the structural member that the imposing load on the girder is framed into.

**7.5.3 Member Design.**

**7.5.3.1 General.**

Design of girder Truss members shall be in accordance with Section 7.3, except as modified herein.

**7.5.3.2 Design for Tension Perpendicular to Grain Forces.**

In addition to meeting the requirements of Section 6.3.3, any connection to a girder Truss that induces tension perpendicular to the grain shall be designed and detailed to limit the cross grain tension forces in accordance with the following subsections.

**7.5.3.2.1 Extent of Connection.**

Where a connection is made with nails or bolts, or other approved fasteners, the connection shall extend past the centerline of the carrying member a minimum distance,  $y$  (see Figure 7.5-1), when it meets the following conditions:

For connections greater than or equal to a distance of  $5 \times d_1$  from the end of the member when  $P_{\perp}$ , exceeds 800 lbs.:

$$y > c [1 - (F_v' 2A_e) / (3P_{\perp})]^{0.5} \tag{E7.5-1}$$

For connections within a distance of  $5 \times d_1$  from the end of the member when  $P_{\perp}$ , exceeds 400 lbs.:

$$y > c [1 - (F_v' 2A_e) / (3P_{\perp}) \times (d_e/d)^2]^{0.5} \tag{E7.5-2}$$

If Equations E7.5-1 or E7.5-2 result in an imaginary number (quantity in brackets is negative), then  $y = 0$ .

where:

$$A_e = d_2 \times d_e$$

$d_e$  = Effective depth of chord member  
 = Dimension from loaded edge of chord to opposite edge of Metal Connector Plate

For connections with nails, bolts, or other approved fas-

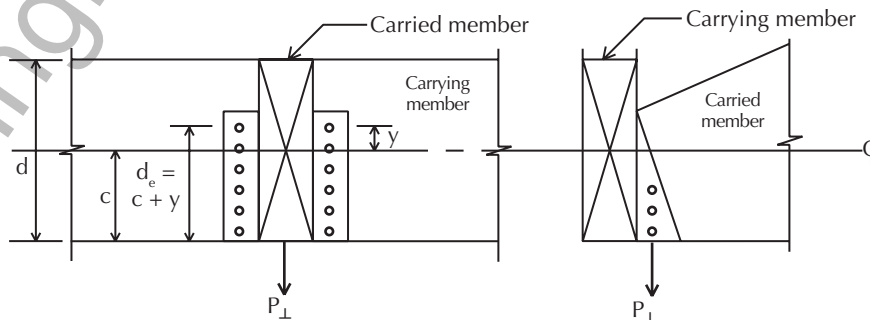

**Figure 7.5-1 Distance (y) to Extend Connection Past Centerline to Enable Carrying Member to Resist Tension Perpendicular-to-Grain Forces.**

teners to a multiple ply girder Truss, the maximum number of plies that shall be used in this area calculation is two.

**7.5.3.2.2 Alternate Extent of Connection.**

Equation E7.5-1 shall be permitted to be solved for an alternate distance,  $y'$ , as shown in Figures 7.5-2 (a) through (c), if any of the following cases are met:

- (a) The girder connection occurs at a Truss joint, and the top most fastener of the connection is located within the Metal Connector Plate Area [see Figure 7.5-2(a)];

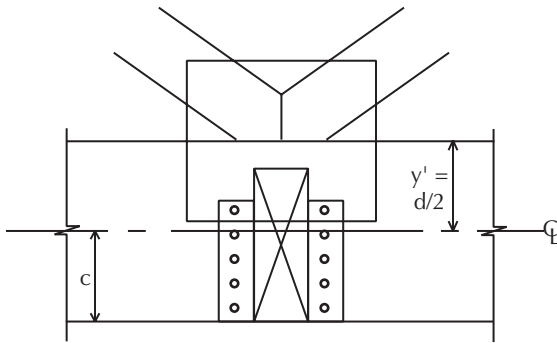

Figure 7.5-2(a)

- (b) Two Metal Connector Plates, one on each side of the girder connection, are placed no more than 12 in. (305 mm) on either side of the connection, and extend below the centerline of the member and top most fastener of the connection [see Figure 7.5-2(b)]; or

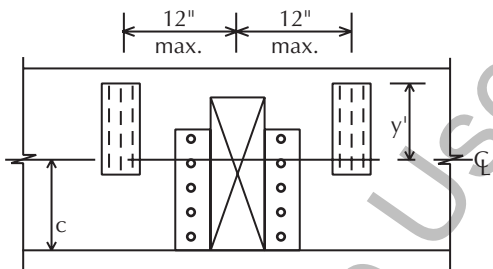

Figure 7.5-2(b)

- (c) A Metal Connector Plate is placed directly under the girder connection, extends below the top most fastener of the connection, and is wider than the connection width [see Figure 7.5-2(c)].

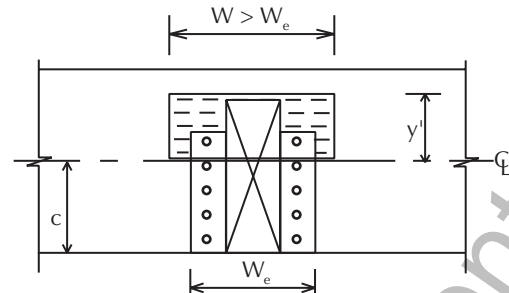

Figure 7.5-2(c)

**7.5.3.3 Design for Tension Perpendicular to Grain.**

Any joint with connector plates in which the net force component perpendicular to the member induces tension perpendicular to the grain, shall require a Metal Connector Plate that extends past the centerline of the member a minimum distance,  $y$  (see Figure 7.5-3), when it meets the following conditions:

For connections greater than or equal to a distance of  $5 \times d_1$  from the end of the member when  $P_{\perp}$ , exceeds 800 lbs. tension:

$$y > c [1 - (F_v'2A_e) / (3P_{\perp})]^{0.5} \tag{E7.5-3}$$

For connections within a distance of  $5 \times d_1$  from the end of the member when  $P_{\perp}$ , exceeds 400 lbs. tension:

$$y > c [1 - (F_v'2A_e) / (3P_{\perp}) \times (d_e/d)^2]^{0.5} \tag{E7.5-4}$$

If Equations E7.5-3 or E7.5-4 result in an imaginary number (quantity in brackets is negative), then  $y = 0$

where:

$$A_e = d_2 \times d_e$$

$d_e$  = Effective depth of chord member  
 = Dimension from loaded edge of chord to opposite edge of Metal Connector Plate

**7.5.3.3.1 Effective Depth Greater Than 85% of Member Depth.**

Any connection where  $d_e$  (see Figure 7.5-3) is at least 85% of the member depth (i.e.,  $d_e = c + y \geq 0.85d$ ) shall be considered to meet the requirements of Section 7.5.3.3.

**7.5.3.4 Reduced Section.**

The design net section of a member shall be calculated to account for a reduction in the gross cross sectional area of a member due to, but not limited to, drilling or notching.

**7.5.3.2.3 Effective Depth Greater Than 85% of Member Depth.**

Any connection where  $d_e$  (see Figure 7.5-1) is at least 85% of the member depth (i.e.,  $d_e = c + y \geq 0.85d$ ) shall be considered to meet the requirements of Section 7.5.3.2.1.

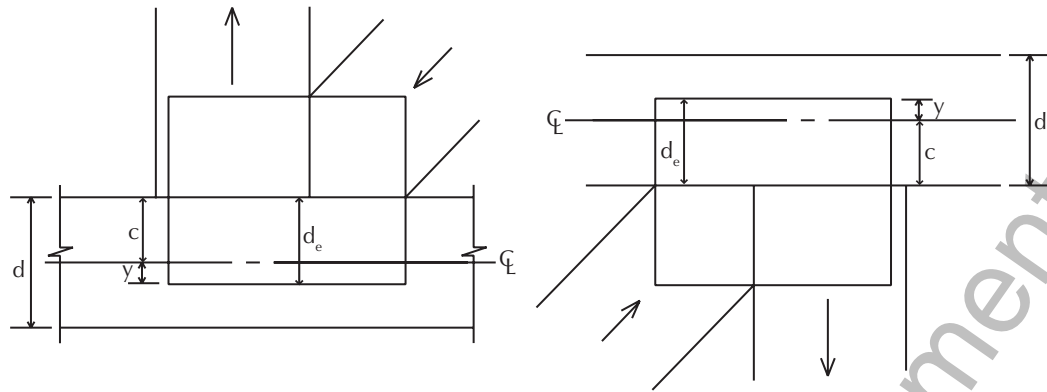

**Figure 7.5-3 Distance to Extend Metal Connector Plate Past Centerline to Resist Tension Perpendicular-To-Grain Forces.**

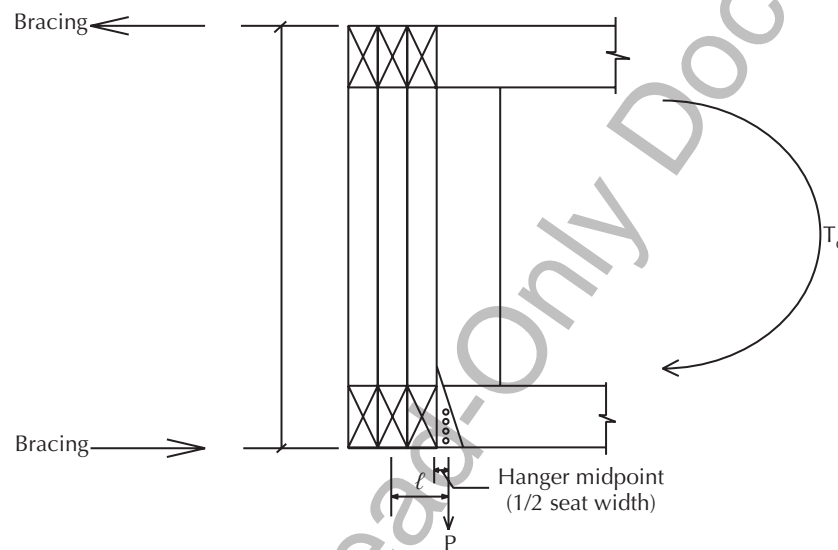

**Figure 7.5-4 Secondary Torsional Stresses,  $T_G$ , Induced by Structural Members Framing into Girders.**

### 7.5.3.5 Torsion.

Girders subject to Truss torsion, induced by structural members framing into them, shall be adequately laterally braced to prevent excessive displacement due to the applied torque,  $T_G$  (see Figure 7.5-4).

### 7.5.3.6 Structural Framing Connections.

Members or structural framing connections shall be so proportioned to resist compression perpendicular to grain stresses induced at the framing connection.

### 7.5.4 Truss-to-Truss Girder Connections.

The connection between a metal-plate-connected wood Truss and a metal-plate-connected girder Truss shall either be a specified commercially available structural framing connection or a specially designed structural framing connection. The connection shall meet the applicable requirements of Section 7.5.3.

### 7.5.5 Ply-to-Ply Connections.

#### 7.5.5.1 Connection of Members.

Girders with up to three plies shall be connected by nailing, bolting, or other approved fasteners in accordance with an approved design criteria. Girders with four or more plies, and having structural members imposing a load on one side of the girder, shall be connected by bolting, a combination of nailing and bolting, or by other approved fasteners. Either nails, bolts, or other approved fasteners shall be designed to transmit 100 percent of the imposed load from one side; the values for more than one type of approved fastener in the same connection shall not be combined. Webs in girders of any number of plies shall be permitted to be joined with nails.

#### 7.5.5.2 Design Load.

Connections shall be designed to transmit load from ply to ply in accordance with the ply-to-ply load distribution assumed in the design of the girder. Connections shall be



adequate to carry the cumulative load of the remaining plies.

**7.5.5.3 Design for Withdrawal Load.**

Connections between the individual plies of a member shall be designed for withdrawal loads equal to two percent of the axial compression force in each ply so connected, for each unbraced length of the member, or these connections shall comply with the provisions of the *ANSI/AWC NDS* for use of  $K_f$  when used per Section 7.3.2. For the purposes of this section, for members braced by sheathing, the unbraced length over which the fasteners carrying this withdrawal load are distributed shall be permitted to be 10 times the cross-section dimension parallel to the dimension in which the sheathing prevents buckling.

**7.5.5.4 Nail Spacing.**

Nail spacing shall be the smaller of the two determined from Sections 7.5.5.2 and 7.5.5.3, but in no case shall the spacing exceed 12 in. (305 mm) on center. Nailing patterns shall be specified on the Truss Design Drawing.

**7.5.5.5 Bolt Spacing.**

Bolt spacing shall be the smaller of the two determined from Sections 7.5.5.2 and 7.5.5.3, but in no case shall the spacing exceed 24 in. (610 mm) on center unless the bolts

are used solely for reasons other than to carry loads addressed by Sections 7.5.5.2 and 7.5.5.3. bolts shall have a diameter no less than 1/2 in. (13 mm) and no greater than 1 in. (25 mm).

**7.6 DEFLECTION**

**7.6.1 Method of Calculation.**

Truss deflection shall be determined by structural analysis in accordance with section 6.1.1.2, except as permitted in section 7.6.2.2 – 7.6.2.3. Deflection due to live load ( $\Delta_{LL}$ ) shall be based on the live load, deflection due to dead load ( $\Delta_{DL}$ ) shall be based on the dead load, and deflection due to total load ( $\Delta_{TL}$ ) shall be based on the full load including both dead and live loads, for each load case. Time dependent deformation under long term loading shall be determined as follows, except for purposes of deflection limitation in accordance with the International Building Code as noted in the next paragraph.

$$\Delta_{LongTerm} = K_{cr} \times \Delta_{LT} + \Delta_{ST}$$

where:

$K_{cr}$  = Creep factor  
 ≥ 2.0 for for trusses using seasoned lumber used in dry service conditions

**Table 7.6-1 Deflection Limits for Non-Cantilevered Portions of Trusses.<sup>3, 5</sup>**

Values given in the table are divisors that are applied to the clear span length,  $L_s$ , to establish a deflection limit (limit =  $L_s$  / specified value).

Member	Deflection due to Live Load Only ( $\Delta_{LL}$ )	Deflection due to Live Load Plus Creep Component of Deflection due to Dead Load ( $\Delta_{CR}$ )	Deflection due to Total Load ( $\Delta_{TL}$ ), when specified <sup>7</sup>
Roof Truss supporting plaster <sup>1</sup>	360	240	240
Roof Truss supporting drywall <sup>1</sup>	240	180	180
Roof Truss not supporting ceilings <sup>1</sup>	180	120	120
Floor Trusses <sup>2</sup> (see footnotes for Trusses supporting ceramic tile)	360	240	240
Top Chord panel <sup>4</sup>	180	120	120
Habitable spaces in Trusses <sup>6</sup>	360		

1. Roofs not having sufficient slope or camber to assure adequate drainage shall be investigated for ponding.
2. Certain floor coverings require more restrictive deflection criteria. For ceramic tile, Truss spacing and appropriate dead load for the installation method, and other aspects of design per *ANSI A108/A118/A136* shall be such that the system passes the requirements of the Building Designer per Chapter 2 of this Standard.
3. Cantilevered and overhang portions of Trusses are subject to deflection limits using the values shown above applied to twice the length of the cantilever,  $L_s$ .
4. Span length for Top Chord panel limits shall be the panel length.
5. Where required by *ACI 530/TMS 402* for Trusses used as a beam or lintel providing support of vertical masonry veneer, a minimum of 1/600 deflection limit shall apply.
6. Limit is for panel deflection of the loaded panel when loaded with 30 psf (14.4 KPa) or greater of live load.
7. The limits for  $\Delta_{LL}$  and  $\Delta_{CR}$  correspond to limits established by typical building codes and shall be applied to all trusses. The limit for  $\Delta_{TL}$  is provided for application when building designers specify such a check due to total load be performed.

≥ 3.0 for trusses using green lumber or for wet service conditions

$\Delta_{\text{LongTerm}}$  = Total Long Term Deflection due to immediate deflection of both short-term and long-term loads and creep deflection of long-term loads

$\Delta_{\text{LT}}$  = Immediate deflection due to the long term component of the design load (immediate deflection due to the portion of load considered to be present over a sustained time period, typically dead load or a portion of dead load)

$\Delta_{\text{ST}}$  = deflection due to short term or normal component of the design load (deflection due to transient loads, typically live load)

For purposes of deflection limitations in accordance with the International Building Code, trusses using only seasoned lumber used in dry service conditions shall determine the deflection for the total load check as follows.

$\Delta_{\text{CR}}$  = Deflection due to Live Load plus Creep Component of Deflection due to Dead Load  
 $= \Delta_{\text{LL}} + (K_{\text{CR}} - 1) \times \Delta_{\text{DL}}$

## 7.6.2 Vertical Deflection Limits.

### 7.6.2.1 Designated Limits.

Truss vertical deflection, determined in accordance with section 7.6.1, shall be limited to the proportions to span length as shown in Table 7.6-1, unless otherwise limited by regulations in the local Jurisdiction or as specified on the Construction Drawings.

### 7.6.2.2 Deflection Using Beam Formulas.

Vertical deflection shall be permitted to be determined using beam formulas as shown in Section 7.6.2.3. When chord lumber having different E values is used, the deflection calculations shall be based on the average E value.

### 7.6.2.3 Deflection Calculation for Parallel Chord Trusses.

For uniformly loaded, simply supported parallel chord Trusses, deflection shall be permitted to be calculated as follows:

$$D = \frac{1.33K_b}{EI_c} \times (1 + 0.015x) \quad (\text{E7.6-1})$$

where:

D = deflection at centerline of Truss (in. or mm)

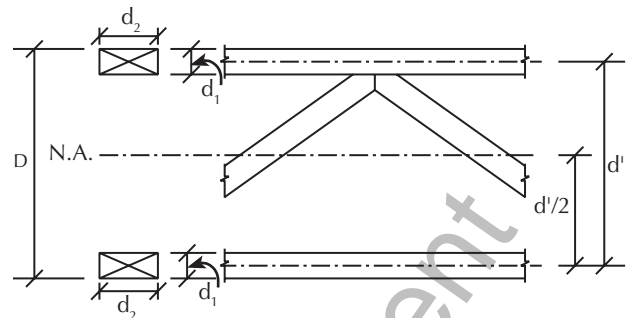

Figure 7.6-1 Dimensions Used to Determine  $I_e$ .

$K_b$  = Load and span effect constant

$$= \frac{(5)(w)(L_s)^4}{384}$$

w = Uniform load (lb/in. or N/mm)

$L_s$  = Clear span (in. or mm)

$I_e$  = Moment of inertia of the cross sectional areas of the Top and Bottom Chords about the neutral axis (N.A.) of the Truss (see Figure 7.6-1)

E = Average modulus of elasticity of Chord lumber (psi or N/mm<sup>2</sup>)

x = Offset of centerline of opening from centerline of Truss (in. or mm) (see Figure 7.6-2); Not to exceed 15 in. (381 mm) for this deflection formula

### 7.6.2.4 Strongbacking.

When specified, strongbacks shall comply with the following installation criteria:

- Strongbacks shall, as a minimum, be 2x6 (nominal), and shall be attached to each Truss with a minimum of three 10d (0.131 in. (3.33 mm) diameter × 3 in. (76 mm) long) nails each to a vertical Web member, or shall be similarly attached to a vertical scab secured at Top and Bottom Chords of each Truss with a minimum of two 10d (0.131 in. (3.33 mm) diameter × 3 in. (76 mm) long) nails into each Chord.
- Strongback cross-section shall be oriented vertically and shall be continuous. When required to be cut, removed, or modified to allow the installation of mechanical and/or plumbing lines, the continuity at adjoining floor sections shall be maintained, and the methods of maintaining continuity shall be specified by the designer specifying the strongbacks.

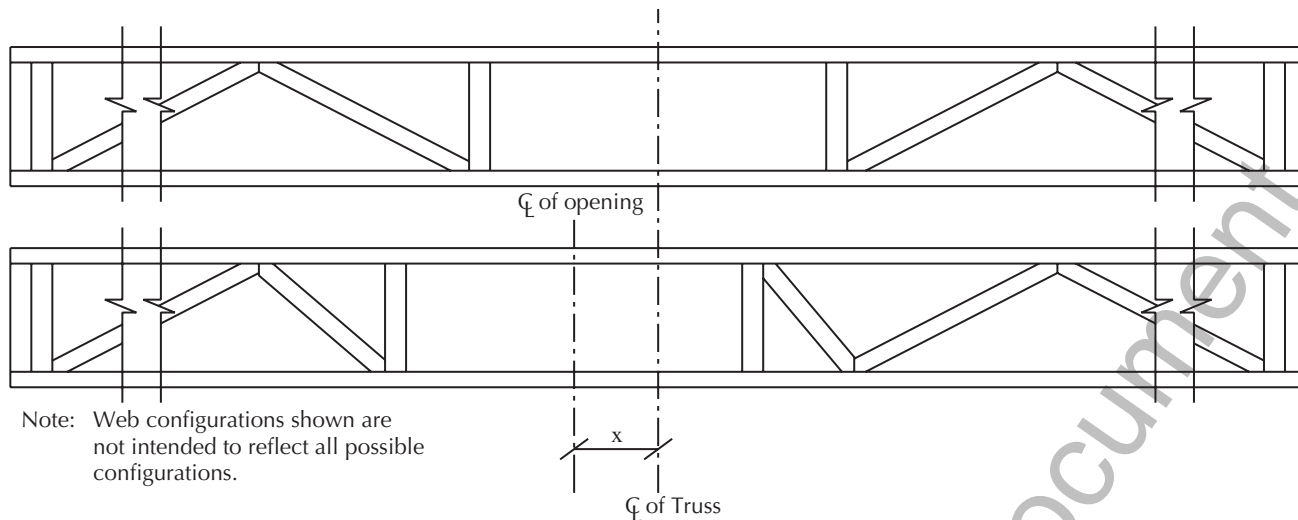

**Figure 7.6-2 Measurement of Opening Offset.**

- (c) Cross bridging shall be permitted as an alternative to strongbacking, as determined by the designer specifying the strongbacks.
- (d) Spacing between multiple strongbacks shall not exceed 10 ft. (3 m) for floor assemblies.
  - (1) When strongbacking is specified to control vibration or protect brittle floor surfaces (such as ceramic tile and natural stone), the Contractor shall locate strongbacking as stipulated on the Truss Design Drawing and as required by the floor surfacing specifications, unless otherwise specified.
  - (2) Strongbacking required to control deflections shall be in accordance with the following criteria unless otherwise specified. When deflection due to live load exceeds 0.67 in. (17 mm), one strongback shall be placed near the centerline of the Truss clear span. When live load deflection exceeds 0.85 in. (22 mm), two strongbacks shall be placed near the centerline of the Truss clear span, or near the third points of the Truss clear span.

ingly. The total horizontal deflection shall be calculated as the sum of the horizontal deflection due to live load plus  $K$  times the horizontal deflection due to dead load, where  $K = K_{cr}$  except that  $K = K_{cr} - 1$  for trusses using only seasoned lumber used in dry service conditions.  $K_{cr}$  shall be determined per section 7.6.1.

### 7.6.3 Horizontal Deflection Limits.

In lieu of specific provisions for lateral movement of Trusses and supports, total horizontal deflection at the Reactions for the design of Trusses shall be limited to 1.25 in. (32 mm) due to total load, and 0.75 in. (19 mm) due to live load. The supporting structure and Truss-to-wall connection shall be designed accord-

## CHAPTER 8

# METAL CONNECTOR PLATE JOINT DESIGN

### 8.1 SCOPE

Each Metal Connector Plate shall be designed in accordance with Chapter 8 of this Standard, to resist all forces and bending moments determined in accordance with Section 6.2.

### 8.2 MINIMUM AXIAL DESIGN FORCES

The minimum axial design force for any Wood Member to be used when designing Metal Connector Plates on Trusses with overall lengths exceeding 16 ft. (5 m) shall not be less than 375 lbs. (1670 N).

### 8.3 LATERAL RESISTANCE

#### 8.3.1 General.

Each Metal Connector Plate shall be designed to transfer the required load without exceeding the allowable load per tooth, or per unit area, based on the species, the orientation of Teeth relative to the load, and the direction of load relative to grain.

#### 8.3.2 Adjustments.

The allowable lateral resistance value,  $V_{LR}'$ , determined in Sections 5.2 and 8.3.3.2 for a given lumber type, plate type, plate/wood orientation, and embedment method, shall be multiplied by all applicable adjustment factors specified in Section 6.4. In addition, heel joints shall be multiplied by the reduction factor specified in Section 8.3.2.2.

#### 8.3.2.1 Exclusion of Area under the Net Area Method.

For Metal Connector Plates rated by the Net Area Method (see Section 5.2.6.2), the plate area tributary to those Teeth within  $\frac{1}{2}$  in. (13 mm) of the ends of members, measured parallel to the grain, and within  $\frac{1}{4}$  in. (6 mm) of the edges of members, measured perpendicular to grain, shall be excluded when determining the Metal Connector Plate coverage for each member of a joint (see Figure 8.3-1). Alternately, if distances greater than those shown in Figure 8.3-1 are used to establish the allowable Net Area design values in Section 5.2.6.2, those End and Edge Distances used shall be excluded from the Metal Connector Plate coverage area.

#### 8.3.2.2 Additional Consideration at Heel Joints.

To allow for moment effects, Metal Connector Plates at heel joints (see Figure 8.3-2) shall be designed to have sufficient capability to withstand the direct axial force of the Top and Bottom Chords using lateral resistance design values multiplied by the following reduction factor,  $H_R$ :

$$H_R = 0.85 - 0.05(12 \tan \theta - 2.0) \quad (\text{E8.3-1})$$

$$0.65 \leq H_R \leq 0.85$$

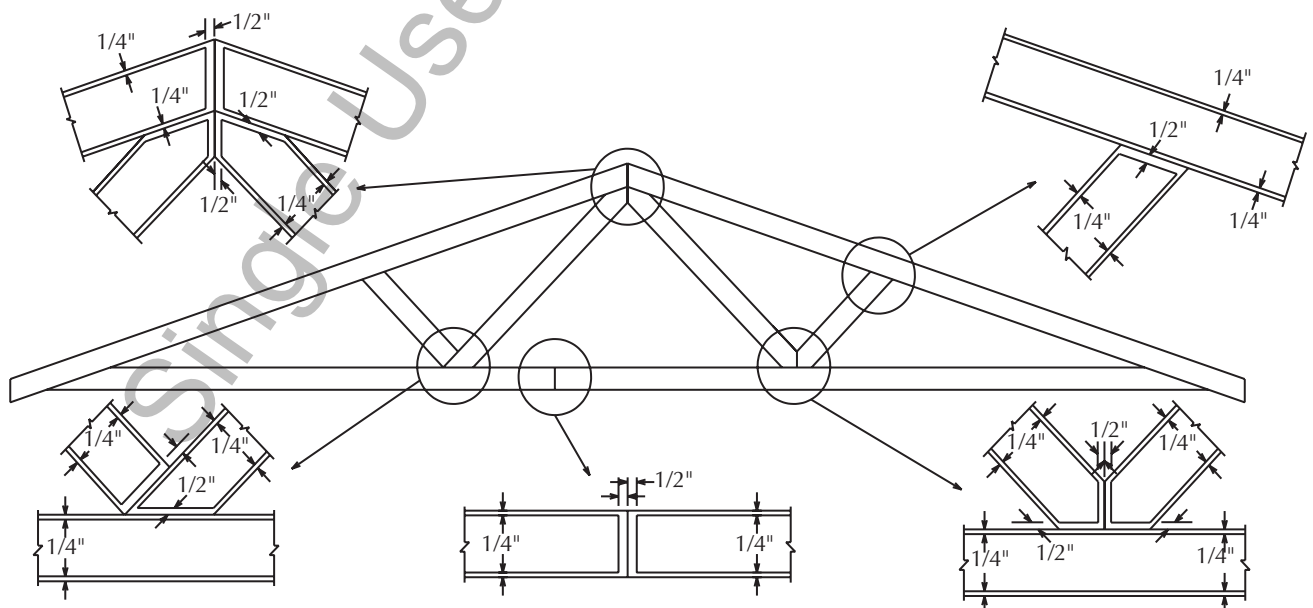

**Figure 8.3-1 End & Edge Distance Requirements for the Net Area Method.**

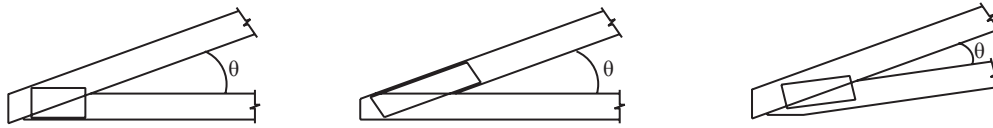

Figure 8.3-2 Heel Joints for which the Reduction Factor,  $H_R$ , Applies.

For conditions with Top Chord slopes of 12/12 or greater and all non-heel joints,

$$H_R = 1.0$$

The End and Edge Distance requirements of Section 8.3.2.1 shall not apply to the design of Metal Connector Plates at the heel joints.

### 8.3.3 Design.

Design of Truss joints for lateral resistance of Metal Connector Plates shall be as follows:

$$A_p = P/V_{LR}' \quad (\text{E8.3-2})$$

where:

$$V_{LR}' = V_{LR}(C_D)(C_M)(C_q)(H_R) \text{ [psi/pair (N/mm}^2\text{/pair)]}$$

$A_p$  = Minimum required Metal Connector Plate contact area for each member, total area for one face (in.<sup>2</sup> or mm<sup>2</sup>)

$P$  = Force in Wood Member (lbs. or N)

$V_{LR}$  = Lateral resistance design value per Metal Connector Plate unit, based on a plate on each face [psi/pair (N/mm<sup>2</sup>/pair)]

#### 8.3.3.1 Number of Teeth Reported for Inspection.

The required number of Teeth,  $N$ , that shall be reported for inspection of plate areas, shall be determined as follows:

$$N = MP/V_{LR}^* \quad (\text{E8.3-3})$$

where:

$$V_{LR}^* = V_{LR}(C_D)(C_M)(H_R) \text{ [psi/pair (N/mm}^2\text{/pair)]}$$

$N$  = Required number of Teeth per face

$M$  = Total tooth density based on a plate on each face (Teeth/sq. in. or Teeth/sq. mm)

#### 8.3.3.2 Load Applied at an Angle.

When load is applied at an angle other than 0 or 90 degrees with respect to lumber grain, the allowable lateral resistance design values shall be as follows:

$V_{LRA\theta}$  = allowable value for Metal Connector Plates loaded at an angle,  $\theta$ , to the grain with the plate axis (tooth slots) parallel to the load [see Figure 8.3-3(a)],

$$= \frac{V_{LRAA} \times V_{LRAE}}{(V_{LRAA} \times \sin^2 \theta) + (V_{LRAE} \times \cos^2 \theta)} \quad (\text{E8.3-4})$$

$V_{LRE\theta}$  = allowable value for Metal Connector Plates loaded at an angle,  $\theta$ , to the grain with the plate axis (tooth slots) perpendicular to the load [see Figure 8.3-3(b)],

$$= \frac{V_{LREA} \times V_{LREE}}{(V_{LREA} \times \sin^2 \theta) + (V_{LREE} \times \cos^2 \theta)} \quad (\text{E8.3-5})$$

When the plate axis is oriented at an angle,  $\alpha$ , from the load direction [see Figure 8.3-3(c)], allowable Design Values shall be determined by linear interpolation between the values  $V_{LRA\theta}$  and  $V_{LRE\theta}$  as follows:

$V_{LR}'$  = allowable value for Metal Connector Plates adjusted for plate and grain orientation,

$$= \frac{((90 - \alpha) \times V_{LRA\theta}) + ((\alpha) \times V_{LRE\theta})}{90} \quad (\text{E8.3-6})$$

#### 8.3.3.3 Metal Connector Plates Resisting Member Compressive Forces.

Metal Connector Plates resisting member compressive forces shall be sized to provide lateral resistance equal to the vectorial sum of the reduced component force(s) normal to the Wood Member interface and 100 percent of the component force(s) parallel to the Wood Member interface. Additionally, Wood Members shall be designed to transmit 100 percent of the remaining component force across the interface in wood-to-wood bearing.

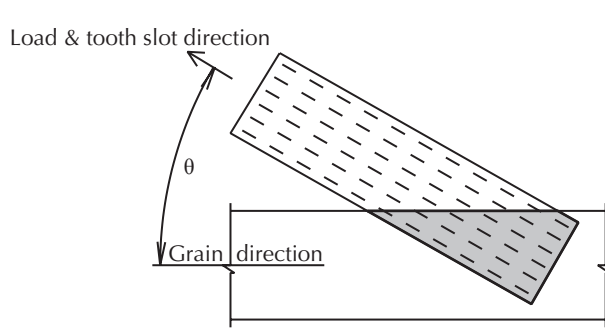

Figure 8.3-3 (a)

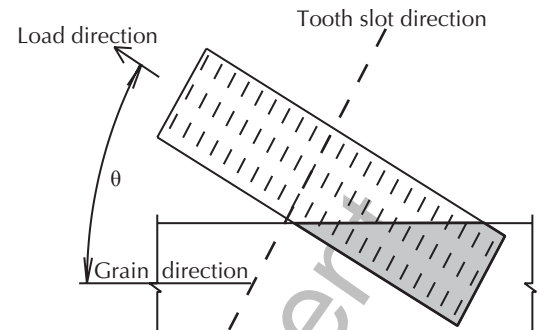

Figure 8.3-3 (b)

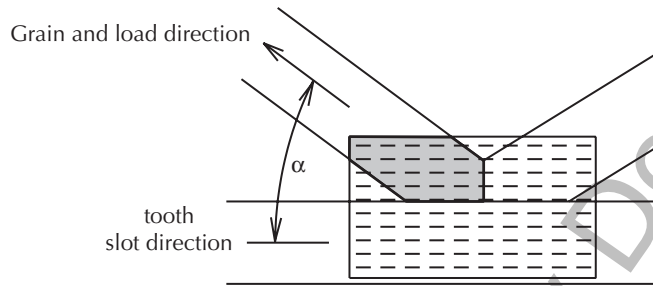

Figure 8.3-3 (c)

$$A_p = P' / V_{LR}' \tag{E8.3-7}$$

where:

$$P' = \sqrt{(P_{ip})^2 + (P_{in} \times C_R)^2}$$

$A_p$  = Minimum required Metal Connector Plate contact area for each member (in.<sup>2</sup> or mm<sup>2</sup>)

$P'$  = Resultant compressive force used for determination of minimum required Metal Connector Plate contact area (lbs. or N)

$V_{LR}$  = Allowable lateral resistance value of Metal Connector Plate [psi/pair (N/mm<sup>2</sup>/pair)]

$C_R$  = Reduction factor for compression force component across the joint interface for Metal Connector Plate design:  $0 \leq C_R \leq 1.0$

$P_{in}$  = Compression force component of the Wood Member under investigation normal to the joint interface (lbs. or N)

$P_{ip}$  = Compression force component of the Wood Member under investigation parallel to the Wood Member interface (lbs. or N)

**8.3.3.3.1 No Wood Member Present.**

If there is no Wood Member present to provide force transfer through wood-to-wood bearing, the Metal Connector

Plate shall be designed for the full 100 percent component.

**8.3.3.3.2 Adjacent Members.**

Metal Connector Plate areas of adjacent members shall be designed to resist this transfer of forces.

**8.4 TENSION**

**8.4.1 Account for Orientation.**

Each Metal Connector Plate shall be designed for tension based on the orientation of the Metal Connector Plate relative to the direction of the load.

**8.4.2 Method.**

The net section of Metal Connector Plates for all tension joints shall be designed using the allowable tensile stress of the metal, adjusted by the Metal Connector Plate tensile Effectiveness Ratio as determined in Section 5.4. Allowable design values in tension (pounds per unit length), for a pair of Metal Connector Plates, one on each face of the joint, shall be determined by the following formula:

$$V_t = 2 (R_t \times F_{st} \times t_l) \tag{E8.4-1}$$

**8.4.3 Required Cross Section.**

The required cross section of the Metal Connector Plate for tension shall be determined as shown in Equation E8.4-2. For chord splices with plates that extend past the chord member,  $W_p$  shall not exceed  $W_p'$  as specified in Sections 8.4.3.1 and 8.4.3.2.

$$W_p = P_t / V_t \tag{E8.4-2}$$

where:

$W_p$  = Gross width of Metal Connector Plate measured parallel to the joint line (in. or mm)

$P_t$  = Axial tensile force in the Wood Member (lbs. or N)

$V_t$  = Allowable design value in tension for a pair of Metal Connector Plates, one on each face of the joint (pli or N/mm)

**8.4.3.1 Maximum Effective Width at Mid-Panel Tension Splices.**

The maximum effective width of Metal Connector Plates for all mid-panel tension chord splices with Metal Connector Plates that extend past the chord member (see Figure 8.4-1) shall be:

$$W_p' = d - d_{le} + x_{max} \tag{E8.4-3}$$

where:

$$x_{max} = 0.25L_{pc}$$

$d$  = Depth of the tension chord (in. or mm)

$d_{le}$  = Distance from the outer edge of the chord to the outer edge of the Metal Connector Plate joining the chord-splice (in. or mm)

$L_{pc}$  = Smaller length of Metal Connector Plate in chord on either side of the splice (in. or mm)

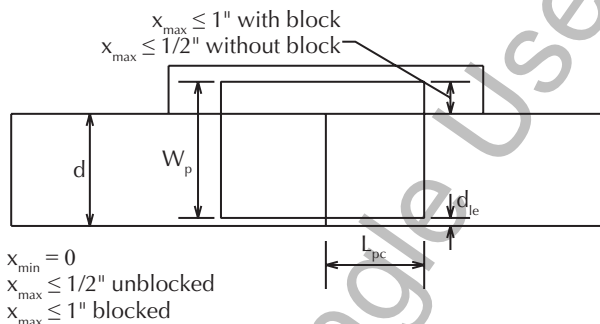

Figure 8.4-1

**8.4.3.2 Maximum Effective Width at Panel Point Tension Splices.**

The maximum effective width of Metal Connector Plates for all panel point tension chord splices with Metal Connector Plates that extend past the chord member shall be:

$$W_p' = d - d_{le} + 1.5 \tag{E8.4-4}$$

where  $d$  and  $d_{le}$  are as defined in Section 8.4.3.1 and are in units of inches.

**8.4.3.3 Connector Plate Designed for Moment.**

When the design of a Truss chord assumes the chord is connected to a joint with a pinned connection, so that no moment is transferred to the joint, and when the Metal Connector Plate at the joint is located so that the center of the steel cross-section on the chord is not on the centerline of the chord, the joint shall be designed in accordance with Section 8.7 for a moment applied simultaneously to the axial force. The moment shall be equal to the axial force normal to the joint times the eccentricity where the eccentricity shall be equal to the distance measured along the joint between the center of the steel cross-section on the chord and the chord centerline (see Figure 8.4-2).

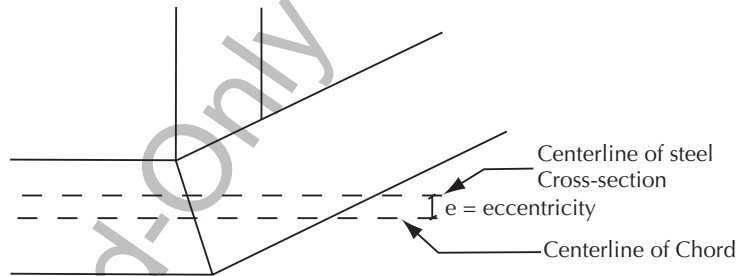

Figure 8.4-2

**8.5 SHEAR**

**8.5.1 General.**

Each Metal Connector Plate shall have sufficient shear capacity based on orientation of the Metal Connector Plate relative to all possible lines of shear.

**8.5.2 Method.**

The net shear section of Metal Connector Plates, for all heel joints and other joints involving shear, shall be designed using the Metal Connector Plate shear design value, adjusted by the Metal Connector Plate shear efficiency as determined in Section 5.3. Allowable Design Values in shear (pounds per unit length or kPa per unit length), for a pair of Metal Connector Plates, one on each face of the joint, shall be determined by the following formula:

$$V_s = 2(R_s \times F_{vs} \times t_1) \tag{E8.5-1}$$

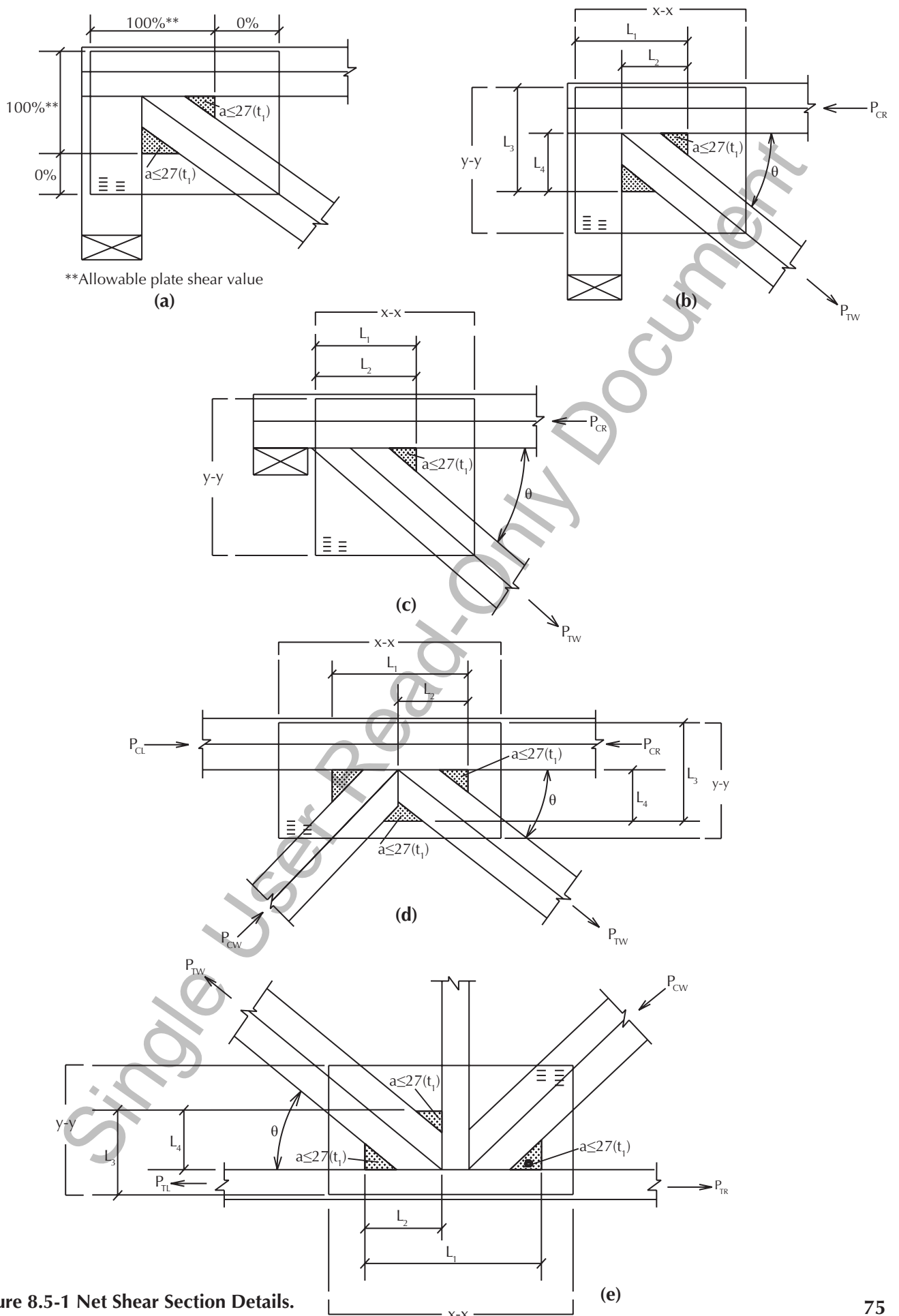

Figure 8.5-1 Net Shear Section Details.



### 8.5.3 Required Cross Section.

The required cross section of the Metal Connector Plate for shear at each joint shall be determined as follows:

$$\ell = P_s / V_s \quad (\text{E8.5-2})$$

where:

$\ell$  = Gross plate dimension parallel to the joint line as limited by Section 8.5.6 (in. or mm)

$P_s$  = Force parallel to the joint across the shear plane (lbs. or N)

$V_s$  = Allowable design value in shear for a pair of Metal Connector Plates, one on each face of the joint (pli or N/mm)

### 8.5.4 Shear Values Parallel and Perpendicular to the Major Axis.

The net shear section for Metal Connector Plates in joints subject to shear shall be designed using Metal Connector Plate shear values parallel and perpendicular to the major axis. The major axis is parallel to the chord. For Metal Connector Plate shear, Equations E8.5-3 and E8.5-4 shall apply for connections detailed in Figures 8.5-1(a)-(e). Alternate design calculations confirmed by test shall be permitted to be used.

At x-x:

$$L_1(V_{s\parallel}) \geq |P_L - P_R| \quad (\text{E8.5-3})$$

At y-y:

$$L_3(V_{s\perp}) \geq P_{TW} \sin\theta \quad (\text{E8.5-4})$$

where:

$P_L$  = Axial force parallel to the grain of the chord to the left of the panel point (lbs. or N)

$P_R$  = Axial force parallel to the grain of the chord to the right of the panel point (lbs. or N)

$P_{TW}$  = Axial force in tension parallel to the grain of the Web (lbs. or N)

$V_{s\parallel}$  = Capacity of a pair of Metal Connector Plates to resist shear along the major axis (pli or N/mm)

$V_{s\perp}$  = Capacity of a pair of Metal Connector Plates to resist shear at 90 degrees to the major axis (pli or N/mm)

### 8.5.5 Combination of Shear Plates and Tension Plates.

Plates that transfer load primarily in shear shall not be used in combination with separate plates that transfer load primarily in tension on the same joint.

### 8.5.6 Prevention of Shear Buckling.

To prevent the occurrence of shear buckling of unsupported plate areas, the plate cross-section of unsupported plate areas shall be considered to have a shear efficiency of zero, except for those portions of the cross-section bordering a triangular area,  $a$ , between two Wood Members (see Figure 8.5-1), not to exceed  $27 \times t_1$ , when 'a' is in sq. in. and  $t_1$  is in in., or 686 times  $t_1$ , when 'a' is in sq. mm, and  $t_1$  is in mm.

## 8.6 COMBINED SHEAR-TENSION

For combined shear and tension in the Metal Connector Plate contact area of Webs, Equation E8.6-1 shall apply for connections detailed in Figures 8.5-1(a)-(e). Alternate design calculations that are confirmed by test shall be permitted to be used.

$$(X_{st} \times L_2) + (Y_{st} \times L_4) > P_{TW} \quad (\text{E8.6-1})$$

where:

$X_{st}$  = Combined shear/tension value for the horizontal projection of a pair of Metal Connector Plates:  $V_{s\parallel} + (\theta/90)(V_{t\perp} - V_{s\parallel})$

$Y_{st}$  = Combined shear/tension value for the vertical projection of a pair of Metal Connector Plates:  $V_{t\parallel} + (\theta/90)(V_{s\perp} - V_{t\parallel})$

$V_{t\parallel}$  = Tensile capacity of the Metal Connector Plate section where the load is applied parallel to the major axis

$V_{t\perp}$  = Tensile capacity of Metal Connector Plate section where the load is applied at 90 degrees to the major axis

## 8.7 COMBINED FLEXURE AND AXIAL LOADING

### 8.7.1 Design of Joints with Plates on Front and Back

#### 8.7.1.1 Design of Steel Section for Effect of Moment.

The moment applied to a Metal Connector Plate used in chord splices (including perimeter joints with changes in slope, i.e., peaks, hips, and scissors centerline joints) shall not exceed the moment capacity defined as follows:

$$M_a = C_m \{ T_1 (W_p + y + z - d_1') + T_2 (4W_p + 2y + 4z - 3d_1') / 3 + C_s (d_1' - z - y) + C_w (d_1' - y) \} / 5 \quad (\text{E8.7-1})$$

where:

$C_m$  = For splices designed using member forces resulting from a structural analysis that produces moment without consideration of interaction of axial compression and transverse deflection on moment (P-delta effect) and when the joint carrying moment is simultaneously subject to a compression force:  $1 - (x/L)(f_c/F_{cEX})$ . For all other situations: 1.0

$x$  = Distance between splice and nearest panel point (in.)

$L$  = Length of panel in which splice is located (in.)

$f_c, F_{cEX}$  = Stresses per Section 7.3.5.1 for Wood Members adjacent to splice (psi)

$y$  = Distance to neutral axis from wood edge with moment-induced compression stress (in.):  $\{t_1 R_t \{F_y (1.8z + W_p) + F_u (W_p + z)\} - 2P_t\} / \{d_2 C + t_1 R_t (1.8F_y + F_u)\}$

$M_a$  = Maximum allowable moment in plane parallel to Metal Connector Plate surface (in. lbs.) acting in direction causing compression on wood edge used to reference plate location (see variable  $z$  below).  $M_a$  shall be considered to equal zero when this equation produces a value less than zero.

$T_1$  =  $2t_1 R_t F_y (W_p - y + z)$

$T_2$  =  $t_1 R_t (F_u - F_y) (W_p - y + z)$

$C_s$  =  $0.8t_1 R_t F_y (y - z)$

$C_w$  =  $yd_2 C$

$R_t$  = Plate tensile Effectiveness Ratio for direction perpendicular to joint, based only on standard tensile testing (steel tensile effectiveness ratios from non-standard tests per section 5.4.4.2.1 shall not be used with equation E8.7-1)

$C$  =  $F_{c\perp} (1.7 F_c^*) / (F_{c\perp} \sin^2 \theta + 1.7 F_c^* \cos^2 \theta)$ , where  $F_c^*$  and  $F_{c\perp}$  are the allowable wood compression stresses parallel and perpendicular to grain for the Wood Members adjacent to the joint line, and  $\theta$  is the angle between the joint line and the length of the Wood Member; use lower  $C$  for either of the Wood Members (psi)

$W_p$  = Plate dimension parallel to joint line, not to exceed  $W_p'$  as specified in Sections 8.4.3.1 and 8.4.3.2 (in.)

$z$  = Distance from compression edge of lumber to compression edge of plate (in.): positive if compression edge of plate is closer than compression edge of lumber to center of wood cross-section; negative if compression edge of lumber is closer than compression edge of plate to center of wood cross-section. For members subject to axial tension force such that there is no compression, the compression edge is defined as that edge with the least tension. The compression edge of the plate shall be limited to the edge of  $W_p'$ .

$F_y$  = Plate steel tensile yield strength (psi)

$F_u$  = Plate steel tensile ultimate strength (psi)

$P_t$  = Force applied normal to joint: positive if tension, negative if compression (lbs.); a value of zero shall be permitted to be used, regardless of the force on the joint, when the equation E8.7-2 is satisfied.

$t_1$  = Plate steel design thickness (in.)

$d_1'$  = Wood cross-section dimensions in the plane of the Truss, measure along the joint cut-line. For differing chord sizes,  $d_1'$  is the dimension of the joint cut-line for the smaller chord (in.)

$d_2$  = Wood cross-section dimensions perpendicular to the plane of the Truss (in.)

Equation E8.7-1 shall be permitted to use  $P_t$  of zero for joints with non-zero normal forces when the combination of applied normal force and applied moment is limited to satisfy the following equation.

$$M/M_a + P/P_a \leq 1.00 \quad (\text{E8.7-2})$$

where:

$M$  = actual (applied) bending moment

$M_a$  = allowable moment per equation E8.7-1 using  $P_t = 0$ .

$P$  = applied force to the joint normal to the line of the joint

$P_a$  = allowable normal force as follows:

$$\text{For compression normal force: } P_a = F_0' d_1 d_2 \quad (\text{E8.7-3})$$

where  $F_0$  is determined per section 7.3.10 for compression bearing on the wood surface of the joint.

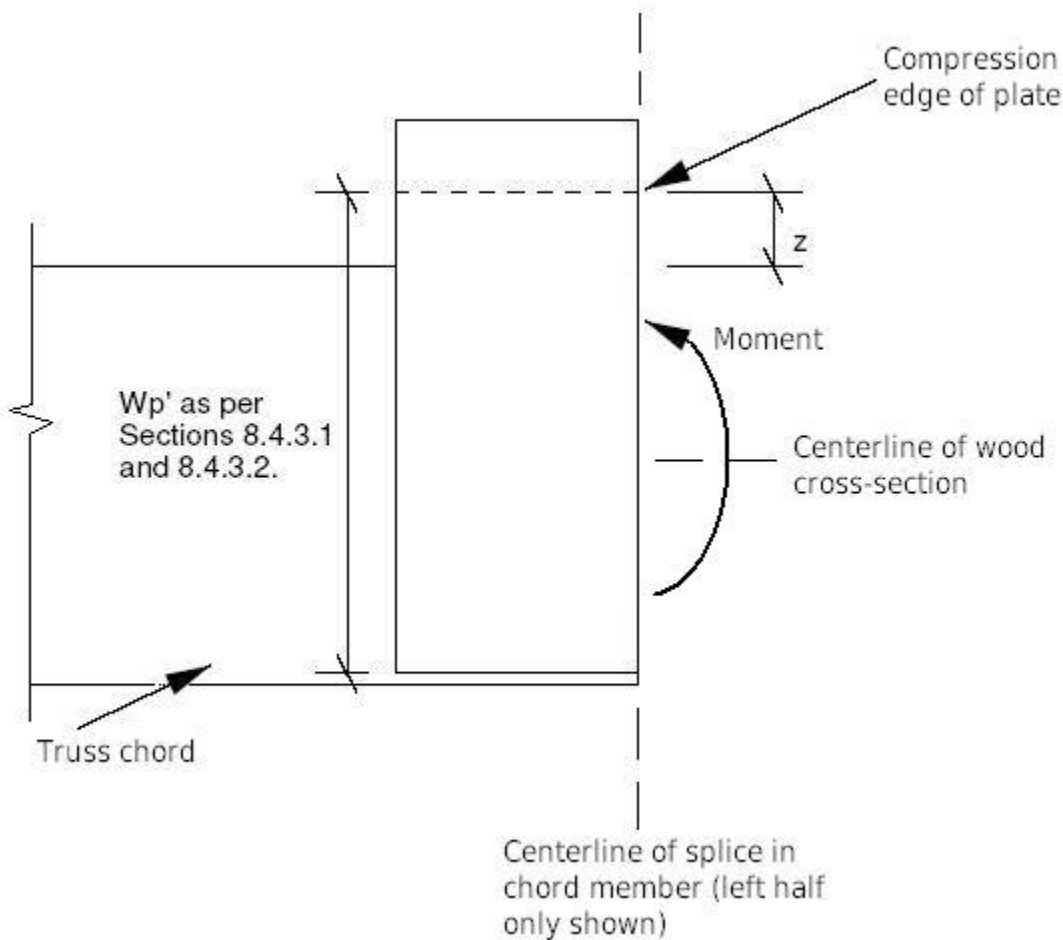

Figure 8.7-1 Illustration of z Distance on Splice Joint

For tension normal force:

$$P_a = V_t W_p \text{ per sec. 8.4.3} \quad (\text{E8.7-4})$$

**8.7.1.2 Design of Plate Lateral Resistance for Effect of Moment.**

The moment applied to a Metal Connector Plate used in chord splices shall not exceed the moment capacity in lateral resistance in any orientation, or the combined capacity for moment and non-moment loads, defined as follows:

$$V_M \leq V_{LR_{min}} \quad (\text{E8.7-5})$$

$$V_M + V_P \leq V_{LR} \quad (\text{E8.7-6})$$

where:

$$V_M = \text{Tooth holding stress due to moment (psi/pair)} \\ = 4M_A / (A_{ef} D)$$

$$V_P = \text{Tooth holding stress resultant of shear/axial loads in wood (psi/pair), equal to the vector addition of shear + axial loads in wood, divided by } A_{ef}$$

$V_{LR}' =$  Allowable tooth holding stress for orientation of  $V_P$ , per Section 8.3 [psi/pair (N/mm<sup>2</sup>/pair)]  
 $V_{LR_{min}}' =$  Minimum allowable tooth holding value for any angle of load at the joint [psi/pair (N/mm<sup>2</sup>/pair)]

$M =$  Design moment load applied to joint in the plane parallel to the Metal Connector Plate surface (lb-in.)

$A_{ef} =$  Effective plate area on one face of each Wood Member at splice joint (in.<sup>2</sup>)

$D =$  Diagonal of a rectangle equivalent to  $A_{ef}$  (in.)

$$= \sqrt{\left(\frac{A_{ef}}{h}\right)^2 + h^2}$$

$h =$  Height of equivalent rectangle, equal to the greatest dimension across  $A_{ef}$  perpendicular to the longest side of  $A_{ef}$

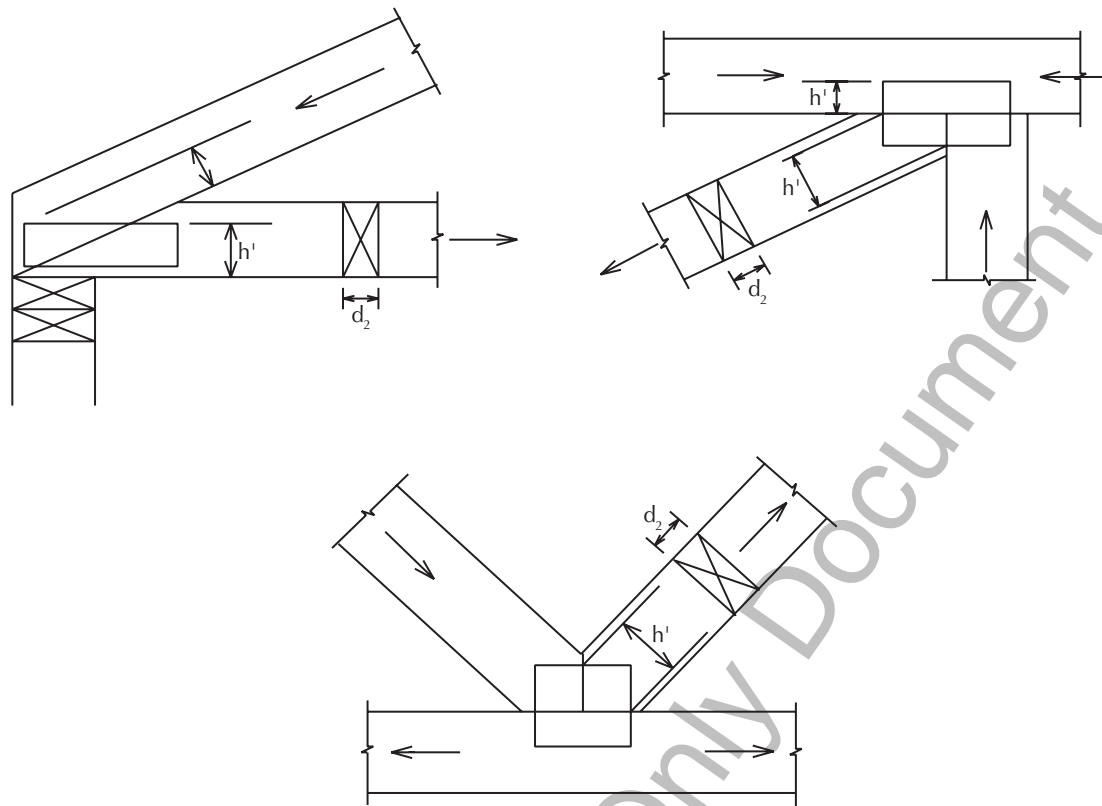

Figure 8.8-1 Reduced Net Section Checks.

**8.7.2 Design of Splice Joints with Plates on Top and Bottom**

Plates on the top and bottom faces of splice joints, such as in trusses with lumber oriented with the wide face in a horizontal plane, shall be designed for moment using the following equation:

$$M \leq (T_{plate} - P_t) * X / 2 \tag{E8.7-7}$$

where:

M = actual (applied) bending moment

T<sub>plate</sub> = Design capacity of a pair of plates in tension (equal to the lesser of lateral resistance and steel tension resistance per sections 8.3 and 8.4, respectively),

P<sub>t</sub> = Applied tension force to splice joint, ≥ 0 (use zero if in compression)

X = d<sub>1</sub>' - (T<sub>plate</sub> - P<sub>t</sub>) / (4 \* d<sub>2</sub> \* F<sub>θ</sub>')

d<sub>1</sub>' = same as defined in sec. 8.7.1.1

F<sub>θ</sub>' = see section 7.3.10

**8.8 NET SECTION LUMBER CHECK (H')**

**8.8.1 Reduced Net Section Checks.**

At all joints, members shall have Metal Connector Plates sized or positioned so that the allowable axial tension stress, F<sub>t</sub>', of any Wood Member, or the allowable axial compressive stress, F<sub>c</sub>\*, of any Wood Member at any joint without wood-to-wood bearing in the direction of the axial force, is not exceeded on the reduced net section, h' times d<sub>2</sub> (see Figure 8.8-1).

**8.8.2 Limit on Tension Introduced into a Wood Member.**

For wood thickness greater than 2 in. nominal (1.5 in. net, 38 mm) with plates embedded only on the surface normal to the thickness, the tension, T, introduced by a single joint into a Wood Member shall not exceed the limits defined by the Truss Designer in pounds per inch (N/mm) of wood width, where wood thickness is the wood cross-section dimension perpendicular to the plane of the Truss and wood width is the wood cross-section dimension in the plane of the Truss, and this tension limit shall be adjusted per Section 6.4, including the application of the repetitive axial stress to Truss chords but not to Truss Webs. This section shall apply only to Wood Members with a cut end under, or within 1 ft. (30 cm) of the edge of, a Metal Connector Plate.

**User (non-mandatory) note:** Unless otherwise justified, TPI's Technical Advisory Committee (TAC) recommends the use of 2300 lbs./in. (403 N/mm) for T.

## 8.9 INTERACTION BETWEEN PLATES AND OTHER FASTENERS

### 8.9.1 Lumber Dowel Bearing Strength Increase.

Metal Connector Plates with integral Teeth shall be permitted to be used to increase the dowel bearing strength of lumber, for dowel-type fasteners embedded into the plated lumber, subject to the limits specified in Sections 8.9.1(a) through 8.9.1(g). Except as mentioned in Sections 8.9.1(a) through 8.9.1(g), fastener design shall otherwise be in accordance with the latest edition of *ANSI/AWC NDS* or other approved design specification.

- (a) Plates shall extend no less than two times the dowel diameter in all directions from the center of the dowel.
- (b) Plates shall extend 2.5 times the dowel diameter in the direction of loading.
- (c) If the fastener load is not parallel to the grain, the plate shall extend across the entire wood depth to within  $\frac{3}{8}$  in. (10 mm) of each edge.
- (d) For bolts loaded at least 40 degrees from the grain direction, the End Distance shall be permitted to be reduced to the greater of four bolt diameters or 2.2 in. (56 mm).
- (e) Fasteners shall be driven through solid steel sections of the plate, or shall be of a greater diameter than the slot dimension parallel to the direction of loading. Holes to permit fastener installation shall be permitted to be drilled in the Metal Connector Plate to a diameter no greater than  $\frac{1}{32}$  in. (0.8 mm) greater than the fastener diameter. When holes are drilled through plated lumber, a backer board shall be used, or other steps shall be taken, to assure that the drilling procedure does not result in the plate on the back face of the lumber being forced out of the wood.
- (f) The dowel embedment strength of the plated cross-section,  $F_{\text{section}}$ , shall be determined using a weighted average based on thickness, as follows:

$$F_{\text{section}} = \frac{(F_{\text{wood}} \times t_{\text{wood}}) + (2 \times f_{\text{steel}} \times t_1)}{(t_{\text{wood}} + 2 \times t_1)} \quad (\text{E8.9-1})$$

where:

$F_{\text{wood}}$  = wood dowel embedment strength as specified by *ANSI/AWC NDS*, or other approved design specification

$t_{\text{wood}}$  = wood thickness penetrated by the dowel

$$f_{\text{steel}} = (1.95 - J \times d)F_y \quad (\text{E8.9-2})$$

where:

$F_y$  = Yield strength of the steel used to produce the Metal Connector Plate

$d$  = Dowel diameter

$J$  = 1.04 when 'd' is in units of in.  
= 0.041 when 'd' is in units of mm

- (g) The portion of dowel load, P, that shall be considered to be introduced into the plate, shall be determined as follows:

$$P = f_{\text{steel}} \times d \times t_1 \quad (\text{E8.9-3})$$

Lateral resistance of the plate for this force shall be limited in accordance with Section 8.3 and in accordance with the following limitation: no Teeth shall be considered effective unless they are within 85 times  $t_1$  of the dowel center.

### 8.9.2 Bolts and Other Fasteners.

Bolts and other fasteners used at a joint, which are not included in the design of the Metal Connector Plate at that joint, shall not penetrate Metal Connector Plates at critical locations. Critical locations are defined as the cross-section of the Metal Connector Plate at the joint line, and within 1 in. (25 mm) of this joint line, and as otherwise identified by the Truss Designer. Holes for such fasteners that are not at critical locations shall be permitted to be made in the Metal Connector Plate, provided the remaining plate area satisfies Section 8.3.

## 8.10 TENSION PERPENDICULAR TO GRAIN

Any joint in which the plate applies a force component causing tension perpendicular to the grain of the chord shall be checked for plate positioning per Section 7.5.3.3.

## 8.11 PLATE POSITIONING TOLERANCE

### 8.11.1 General.

A tolerance for Metal Connector Plate positioning shall be calculated for each joint selected for inspection per Chapter 3 of this Standard. This tolerance shall be based

on calculations as defined in Chapter 8 and Sections 7.3.7.4 and 7.3.8. This tolerance shall be depicted in a Joint QC Detail, which shall be provided for any joint being inspected per Section 3.7.

#### 8.11.2 Joint QC Detail Information.

The tolerances for plate positioning shall be shown for the fabrication tolerance set by the Truss Manufacturer, as well as for a 0 percent fabrication tolerance ( $C_q = 1.00$ ). For each fabrication tolerance, the Joint QC Detail will include a polygon consisting of no less than four points at the maximum allowable positive and negative placement tolerances in two perpendicular directions, where the x-axis and y-axis are parallel and perpendicular to the plate length and/or joint line, respectively. Maximum allowable distances shall be based off of the center point of the Truss plate and relative to the Wood Members at that joint. The Joint QC Detail shall also include the minimum number of required effective Teeth for each plate contact area and a representation of the allowable area for characteristics reducing the plate contact area per the fabrication tolerance set by the Truss Manufacturer. An example Joint QC Detail is shown in Figure 3.7-1.

#### 8.11.3 Joint Stress Index.

The JSI reported on the Joint QC Detail shall be the JSI determined for the plate located at the intended position and orientation using the selected  $C_q$  value.

*User (non-mandatory) note:* TPI's Technical Advisory Committee (TAC) recommends using a selected  $C_q$  value equal to 0.8.

#### 8.11.4 Minimum Plate Positioning Tolerance.

For joints designed using standard steel tension values, the plate positioning tolerance shall be  $\frac{1}{2}$  in. (13 mm) minimum in any direction for all design stress checks other than lateral resistance, and shall be  $\frac{1}{8}$  in. (3mm) minimum in any direction for lateral resistance design stress checks. For joints designed using non-standard steel tension values determined per Section 5.4.4.2.1, the plate positioning tolerance shall be  $\frac{1}{16}$  in. (1.5 mm) minimum in any direction for all design stress checks other than lateral resistance, and shall be  $\frac{1}{8}$  in. (3 mm) minimum in any direction for lateral resistance design stress checks. For joints designed using non-standard steel tension values, the Truss Design Drawing shall identify those joints as having special positioning requirements in accordance with Section 3.7.2.2.

#### 8.11.5 Plate Rotation.

All design checks in Chapter 8 shall account for plate rotations of plus and minus 10 degrees, or as specified

in the Truss Manufacturer's In-Plant Quality Assurance Program, about the plate center at its design position, including the determination of the plate positioning tolerance polygon in Section 8.11. For conditions where the Truss Design used a plate rotation tolerance less than 10 degrees, the maximum allowable plate rotation shall be specified on the Truss Design Drawing.

Single User Read-Only Document

Single User Read-Only Document





**Truss Plate Institute**  
*Connecting the Truss Industry*

218 North Lee Street, Ste. 312  
Alexandria, VA 22314  
(703) 683-1010  
[www.tpinst.org](http://www.tpinst.org)